

# **The Role of Research in a Regulatory Context (RRRC-2)**

Workshop Proceedings  
Paris, France  
5 December 2007

© OECD 2008  
NEA N° 6377

## ORGANISATION FOR ECONOMIC CO-OPERATION AND DEVELOPMENT

The OECD is a unique forum where the governments of 30 democracies work together to address the economic, social and environmental challenges of globalisation. The OECD is also at the forefront of efforts to understand and to help governments respond to new developments and concerns, such as corporate governance, the information economy and the challenges of an ageing population. The Organisation provides a setting where governments can compare policy experiences, seek answers to common problems, identify good practice and work to co-ordinate domestic and international policies.

The OECD member countries are: Australia, Austria, Belgium, Canada, the Czech Republic, Denmark, Finland, France, Germany, Greece, Hungary, Iceland, Ireland, Italy, Japan, Korea, Luxembourg, Mexico, the Netherlands, New Zealand, Norway, Poland, Portugal, the Slovak Republic, Spain, Sweden, Switzerland, Turkey, the United Kingdom and the United States. The Commission of the European Communities takes part in the work of the OECD.

OECD Publishing disseminates widely the results of the Organisation's statistics gathering and research on economic, social and environmental issues, as well as the conventions, guidelines and standards agreed by its members.

\* \* \*

*This work is published on the responsibility of the Secretary-General of the OECD. The opinions expressed and arguments employed herein do not necessarily reflect the official views of the Organisation or of the governments of its member countries.*

## NUCLEAR ENERGY AGENCY

The OECD Nuclear Energy Agency (NEA) was established on 1<sup>st</sup> February 1958 under the name of the OEEC European Nuclear Energy Agency. It received its present designation on 20<sup>th</sup> April 1972, when Japan became its first non-European full member. NEA membership today consists of 28 OECD member countries: Australia, Austria, Belgium, Canada, the Czech Republic, Denmark, Finland, France, Germany, Greece, Hungary, Iceland, Ireland, Italy, Japan, Luxembourg, Mexico, the Netherlands, Norway, Portugal, Republic of Korea, the Slovak Republic, Spain, Sweden, Switzerland, Turkey, the United Kingdom and the United States. The Commission of the European Communities also takes part in the work of the Agency.

The mission of the NEA is:

- to assist its member countries in maintaining and further developing, through international co-operation, the scientific, technological and legal bases required for a safe, environmentally friendly and economical use of nuclear energy for peaceful purposes, as well as
- to provide authoritative assessments and to forge common understandings on key issues, as input to government decisions on nuclear energy policy and to broader OECD policy analyses in areas such as energy and sustainable development.

Specific areas of competence of the NEA include safety and regulation of nuclear activities, radioactive waste management, radiological protection, nuclear science, economic and technical analyses of the nuclear fuel cycle, nuclear law and liability, and public information. The NEA Data Bank provides nuclear data and computer program services for participating countries.

In these and related tasks, the NEA works in close collaboration with the International Atomic Energy Agency in Vienna, with which it has a Co-operation Agreement, as well as with other international organisations in the nuclear field.

### © OECD 2008

No reproduction, copy, transmission or translation of this publication may be made without written permission. Applications should be sent to OECD Publishing: [rights@oecd.org](mailto:rights@oecd.org) or by fax (+33-1) 45 24 99 30. Permission to photocopy a portion of

this work should be addressed to the Centre Français d'exploitation du droit de Copie (CFC), 20 rue des Grands-Augustins, 75006 Paris, France, fax (+33-1) 46 34 67 19, ([contact@cfcopies.com](mailto:contact@cfcopies.com)) or (for US only) to Copyright Clearance Center (CCC), 222 Rosewood Drive Danvers, MA 01923, USA, fax +1 978 646 8600, [info@copyright.com](mailto:info@copyright.com).

*Cover credits: J. Ha, KAERI (Korea); R. Yang, EPRI (USA).*

## FOREWORD

At their meeting of December 2006, the NEA Committee on Nuclear Regulatory Activities (CNRA) and the NEA Committee on the Safety of Nuclear Installations (CSNI) agreed to hold a workshop on the Role of Research in a Regulatory Context in order to take stock of new findings and progress since the previous NEA workshop on this subject in 2001. The one-day workshop was to be held in conjunction with the CNRA and CSNI meetings of December 2007.

An Organising Committee consisting of CNRA and CSNI Bureau members and three CSNI representatives was set up for the purpose of defining the workshop's objective, scope and overall framework, and in order to facilitate the participation of key senior experts. It was agreed, among others, that all main actors in regulatory research, i.e. regulators, research institutions and industry, be represented in the workshop panels.

The workshop was organised around an opening session, three panel sessions addressing a specific issue each, and a closing session, as shown below:

Opening:	Scene Setting – Changes and CSNI/CNRA achievements since 2001.
Session 1:	Research needs and facility utilisation for operating reactors.
Session 2:	Research and facility needs for new reactors (G-III, G-III+).
Session 3:	R&D and facility infrastructure for advanced (G-IV) reactors.
Closing Session:	Summary and recommendations.

A concise questionnaire was distributed to relevant organisations in advance of the workshop to gather basic information regarding member countries' current plans in the area of regulatory research.

These proceedings include the papers that were presented at the workshop as well as a summary of the workshop's discussions and main findings.



## TABLE OF CONTENTS

<b>Foreword</b> .....	3
<b>1. Workshop outline</b> .....	7
1.1 Objective .....	7
1.2 Organisation .....	7
1.3 Scope .....	8
1.4 Programme .....	9
<b>2. Workshop summary and conclusions</b> .....	11
2.1 Summary of the presentations .....	11
2.1.1 Opening session .....	11
2.1.2 Session 1: Research needs and facility utilisation for operating reactors .....	11
2.1.3 Session 2: Research needs and facility utilisation for new reactors (G-III, G-III+) ..	12
2.1.4 Session 3: R&D and facility infrastructure for advanced reactors (G-IV).....	12
2.2 Summary of the workshop chairs.....	13
2.2.1 Motivation for safety research .....	13
2.2.2 Main subjects of safety research .....	14
2.2.3 Organisation of research .....	15
2.3 Conclusions and recommendations for the CNRA and the CSNI.....	16
2.3.1 Conclusions and recommendations drawn by the CNRA chair.....	16
2.3.2 Conclusions and recommendations drawn by the CSNI chair.....	16
<b>3. Presentations</b> .....	19
<i>Opening session: Changes and CSNI/CNRA achievements since 2001</i> .....	19
<i>Dr. Kunihisa Soda, Commissioner, Nuclear Safety Commission, Japan</i> New perspective and R&D challenges regarding the safety development and use of nuclear energy .....	21
<i>Mr. Jacques Repussard, Director-General, IRSN, France</i> CSNI initiatives and lessons learned that can be brought forward in the future: expectations arising from nuclear renaissance .....	25

<b>Session 1: Research needs and facility utilisation for operating reactors</b> .....	29
<i>Ms. Marie-Pierre Comets, Commissioner, ASN, France</i>	
Research, a key for improving nuclear safety and radiation protection: a regulatory viewpoint.....	31
<i>Dr. Kiyoharu Abe, Technical Counsellor, JNES, Japan</i>	
Selection and prioritisation of safety research projects for existing reactors: a new regulatory approach in Japan .....	35
<i>Dr. Rosa Yang, Vice-President, EPRI, United States</i>	
Industry perspective on R&D needs.....	45
<i>Dr. Jean-Claude Micaelli, IRSN, France</i>	
Organisation of safety research programmes and infrastructure for existing reactors .....	55
<b>Session 2: Research and facility needs for new reactors (G-III, G-III+)</b> .....	63
<i>Dr. Lasse Reiman, Director, STUK, Finland</i>	
Research requirements emerging from licensing and new plant construction: lessons learned .....	65
<i>Dr. Jaejoo Ha, Vice-President, KAERI, Korea</i>	
Evolution of safety research demands for new reactor designs and ways to address them.....	75
<i>Mr. Jean-Pierre Hutin, Vice-President, Power Generation Sector, EDF, France</i>	
A utility viewpoint on R&D needs to support design, construction and operation of Generation III reactors .....	85
<i>Mr. Bill Borchardt, Director, Office of new reactors, USNRC, United States</i>	
USNRC perspective on research for near-term reactors .....	93
<b>Session 3: R&amp;D and facility infrastructure for advanced (G-IV) reactors</b> .....	97
<i>Mr. Jean-Louis Carbonnier, CEA, France</i>	
Safety issues and related &D for Gen-IV concepts.....	99
<i>Mr. Yutaka Sagayama, JAEA, Japan</i>	
Safety design concept of advanced sodium fast reactor .....	107
<i>Mr. Yoshio Shimakawa, MFBR, Japan</i>	
Safety design and R&D issues for advanced sodium-cooled fast reactors.....	113
<i>Mr. Michael Johnson, USNRC, United States</i>	
Strategic decisions on research for advanced reactors: USNRC perspective.....	121
<b>List of participants</b> .....	125

## **1. WORKSHOP OUTLINE**

### **1.1 Objective**

The workshop intended to:

- Promote the exchange of experience among regulators, research managers and industry on the needs, priorities and foreseeable trend for safety research in a regulatory context and on the means that are or can be used for effectively performing such research.
- Review the progress made since the 2001 Forum on the same subject, including the outcomes from initiatives taken in response to the Forum recommendations.
- Set forth the high priority safety issues currently and in the near-term for operating plants and new reactor construction, identifying possible mismatches between what needs to be done and what is being performed.
- Bring forward the challenges that the nuclear community will be faced with in the long term for performing safety evaluations of advanced reactor designs, and envisage means for organising the research and the infrastructure that will be needed.
- Discuss the roles of regulators, research and development institutions and industry in continuing, setting up and performing research programmes, and determining the conditions necessary for a proper balance in cooperative regulatory and industry research and areas where their joint efforts can be strengthened.
- Through the above, provide input to the CSNI and the CNRA operating plans regarding subjects that need to be addressed by the Committees and strategies that need to be put in place for new research programmes and new support facilities.

### **1.2 Organisation**

The workshop was organised around an opening, three panel sessions each addressing a specific issue, and a closing session. Each panel consisted of three to four panelists. The panel members represented regulators, research organisations and industry. Each panelist made a 15-minute presentation covering the subjects to be dealt with and related points of discussion. The presentations provided a reasonably comprehensive overview of the international perspective on the subject. The overall discussion for each session was open to all workshop participants lasted for ~ 45 minutes. The objective of the concluding session was to summarise the main elements discussed and derive conclusions from the first three sessions, including any relevant recommendations to the CSNI and the CNRA.

### 1.3 Scope

The workshop consisted of four sessions addressing the following subjects:

- Opening: Scene-setting, changes and CSNI/CNRA achievements since 2001.
- Session 1: Research needs and facility utilisation for operating reactors.
- Session 2: Research and facility needs for new reactor construction (G-III, G-III+).
- Session 3: Need of R&D and build up of a facility infrastructure for advanced (G-IV) reactors.
- Closing Session: Summary and recommendations.

*The Opening* “Scene-setting, changes and CSNI/CNRA achievements since 2001” was intended to provide:

- a) The scene-setting including the main changes that have occurred since 2001, particularly the change in perspective regarding the future use of nuclear energy and the expectations arising from the present nuclear renaissance, and how these changes should be captured in designing the future for nuclear safety research.
- b) The initiatives that CSNI has taken in response to the 2001 workshop and their main outcomes, addressing whether they are still a valid approach for safety research in the future.

*Session 1* “Research needs and facility utilisation for operating reactors” aimed to address:

- a) The regulatory needs in the near term future (~10 years) for operating reactors, the way they are being or should be addressed in different countries and/or internationally.
- b) Industry perspective on R&D needs for operating reactors considering lessons learned from operating experience and from research, areas where continued or new research is needed and ways to address it in different countries and/or internationally.
- c) The way the research world is or should be organised and possible means to maintain a sufficient level of efficient facility infrastructure supporting operating reactors.

*Session 2* “Research and facility needs for new reactor construction (G-III, G-III+)” areas to discuss:

- a) The regulatory perspective regarding the needs that have already emerged or that are likely to emerge in the mid-term future (~10 years) for new (G-III, G-III+) reactors, the way they are being or should be addressed in different countries and/or internationally. Requirements for result oriented research from a regulators viewpoint and CNRA/CSNI interaction for addressing current and near term needs.
- b) The industry perspective on current research needs and near term needs for new (G-III, G-III+) reactors, the way they are being or should be addressed in different countries and/or internationally. Requirements for result oriented research from an industry viewpoint.
- c) The perspective of the research institutions regarding the evolution of the safety research demands; the effects of internationalisation of research; the interaction of research institutions with regulators and industry.



*Session 3* “Need of R&D and build up of a facility infrastructure for advanced (G-IV) reactors” was to focus on:

- a) The challenges associated with the safety assessment of advanced reactor concepts and with the introduction of new materials and technologies.
- b) The strategic decisions that will need to be taken in terms of what safety research is needed, how it will be organized and carried out, what large facilities and other infrastructural measures may be needed, the role of and co-operation among the regulatory, research and industry spheres and who is to make these decisions.
- c) The role of international research on the above and in particular the role of NEA and CSNI/CNRA in undertaking initiatives on international collaborative research in support of advanced reactors, taking also into account the time frame envisaged for such initiatives

*The Closing session* developed the Workshop summary and recommendations.

## **1.4 Programme**

### **Opening Session**

#### **Scene setting: Changes and CSNI/CNRA achievements since 2001**

*L. Echávarri, NEA Director General, Introduction*

1. *K. Soda, Nuclear Safety Commission, Japan*  
New perspective and R&D challenges regarding the safe development and use of nuclear energy.
2. *J. Repussard, IRSN, France*  
CSNI initiatives and lessons learned that can be brought forward in the future: expectations arising from nuclear renaissance.

### **Session 1**

#### **Research needs and facility utilisation for operating reactors**

3. *M.P. Comets, ASN, France*  
Research, a key for improving nuclear safety and radiation protection: a regulator viewpoint.
4. *K. Abe, JNES, Japan*  
Selection and prioritisation of safety research projects for existing reactors: a new regulatory approach in Japan.
5. *R. Yang, EPRI*  
Industry perspective on R&D needs.
6. *J.C. Micaelli, IRSN, France*  
Organisation of safety research programmes and infrastructure for existing reactors.

*Discussion and recommendations*

## **Session 2**

### **Research and facility needs for new reactors (G-III, G-III+)**

7. *L. Reiman, STUK, Finland*  
Research requirements emerging from licensing and new plant construction: lessons learned.
8. *J.J. Ha, KAERI, Republic of Korea*  
Evolution of safety research demands for new reactor designs and ways to address them.
9. *J.P. Hutin, EDF, France*  
A utility viewpoint on R&D needs to support design, construction and operation of Generation III reactors.
10. *W. Borchardt, US NRC, USA*  
USNRC perspective on research for near term reactors.

*Discussion and recommendations*

## **Session 3**

### **R&D and facility infrastructure for advanced (G-IV) reactors**

11. *J.L. Carbonnier, CEA, France*  
Safety issues and related R&D for Gen-IV concepts.
12. *Y. Sagayama, JAEA, Japan*  
Safety design concept of advanced sodium fast reactor.
13. *Y. Shimakawa, MFBR, Japan*  
Safety design and R&D issues for advanced sodium-cooled fast reactors.
14. *M. Johnson, US NRC, USA*  
Strategic decisions on research for advanced reactors: USNRC perspective.

*Discussion and recommendations*

## **Closing Session**

### **Summary and recommendations**

15. *J. Repussard and K. Soda, Workshop Chairs*  
Sessions summary.
16. *M. Weightman, CNRA Chair*  
Recommendations and input for CNRA.
17. *L. Hahn, CSNI Chair*  
Recommendations and input for CSNI.

*L. Echávarri, NEA Director General. Closure.*

## 2. WORKSHOP SUMMARY AND CONCLUSIONS

### 2.1 Summary of the presentations

#### 2.1.1 Opening session

*Mr. Echávarri, Director General of the NEA*, welcomed the Workshop participants noting with satisfaction the large attendance. He recalled that safety research has for long time been the focus of CSNI and that a number of safety projects have been deployed in the last several years. He mentioned that a statement was approved at the last meeting by the NEA Steering Committee for Nuclear Energy regarding a government role in ensuring qualified human resources in the nuclear field. The statement emphasizes among others the role of Governments in encouraging large, high-profile, international R&D programmes, which attract students and young professionals to become the nuclear experts required for the future.

*Dr. Soda, Commissioner of the Japanese Nuclear Safety Commission* and Workshop co-chair, gave an introduction on the new R&D perspectives and challenges. His presentation underscored that regulatory research is to provide the technical basis for decision making by regulatory bodies and that this basis should be updated to meet the latest development of technology. The main recommendations made at the 2001 Workshop remain valid. The knowledge base and expertise accumulated in the past should be incorporated in an integrated approach to the design, construction, operation and maintenance of next generation reactors.

*Mr. Repussard, Director General of the French IRSN* and Workshop co-chair, observed that the NEA-CSNI initiatives since 2001 have been successful in that they facilitated international co-operation, produced relevant information on safety questions, contributed to keeping unique facilities running and helped transferring knowledge to younger generations. This CSNI experience should be put to work in developing a new roadmap for future CSNI activities regarding the generation and promotion of long-term R&D plans, including infrastructure, human resources and funding aspects. The CSNI should also consider organising an open dialogue with all stakeholders, i.e. governments, regulators, industry and also NGOs.

#### 2.1.2 Session 1: Research needs and facility utilisation for operating reactors

*Ms. Comets, Commissioner of ASN, France*, pointed out that research is needed for regulatory decision making and that as final users of research, regulators should make sure that their needs are accounted for in the programmes. The experience of other regulatory bodies that are involved with the definition of research programmes was mentioned, together with specific examples of safety research themes and noting the importance of having experimental facilities.

*Mr. Abe, Senior Advisor to the Chairman of JNES, Japan*, provided an example of practice in the priority setting for safety research projects on current reactors, including the role of regulator, industry, academia and research centres. In particular, he described how operational experience is factored in the regulatory response and in developing research needs. He noted that Japan keeps a good balance between being an active member of the NEA-CSNI joint projects and preserving domestic research activities.

*Ms. Yang, Vice-President for Innovation, EPRI, USA*, gave an overview of industry perspective on R&D needs. The licensing of plant life extension is a key industry objective, requiring extensive research on degradation mechanisms. Fuel performance, i.e. better fuel economics, improved fuel reliability and definition of fuel safety criteria at high burn-up, constitute another industry research priority. The effective use of digital I&C as means to reduce scope of human errors and to improve ability to cope with incidents is also a subject of extensive research.

*Mr. Micaelli, Deputy Director at IRSN, France*, reviewed the main drivers of safety research, noting that challenging research is an excellent means to preserve know-how and professional skills. International efforts such the NEA-CSNI joint projects are an efficient means to support experimental infrastructure for safety research, while providing useful experimental results. Other initiatives, e.g. within the EU, aimed at developing networks of international expertise and infrastructure were also mentioned.

### **2.1.3 Session 2: Research needs and facility utilisation for new reactors (G-III, G-III+)**

*Mr. Reiman, Director at STUK, Finland*, focused on research requirements and lessons learned on licensing and construction of new plants. He mentioned design changes such as severe accident mitigation features, passive systems, part inspectability and digital I&C as items that require attention. Safety culture of suppliers was also mentioned as an important consideration. The NEA co-ordination of international research programmes was valued for its role in maintaining test facilities and competent international research networks.

*Mr. Ha Vice-President of KAERI, Korea*, presented the trend and emerging demands for new reactor research. He noted in particular the increased concentration of plants, the longer design lifetime, more extreme environments and stronger concerns on security as drivers for future research. He mentioned passive safety systems, severe accident mitigation features and new materials as important elements of design progress, and risk-informed approaches and advanced analysis tools as relevant method evolution. He concluded that the NEA-CSNI joint project approach looks right and deserve further streamlining.

*Mr. Hutin, Vice-President for Power Generation, EDF, France*, underscored the importance of harmonizing design and licensing methodology for new reactors. He addressed the use of probabilistic approaches, the adoption of advanced man-system interface systems to facilitate plant operation and maintenance, better inspections methods and the progress on numerical simulation. New fuels and new fuel cycle technologies can be applied to improve efficiency and to close the fuel cycle. Regarding research, he saw it also as an opportunity to close issues that have been sufficiently investigated. He concluded that international programmes enable to share costs and build consensus, and the OECD NEA should play a major role to support international co-operation.

*Mr. Borchardt, Director of the Office of New Reactors, USNRC*, explained that on the background of the resurgence of nuclear power in the US, several new plant design have been proposed, for which the USNRC performs licensing reviews and, if necessary, conducts confirmatory tests. Research has provided the basis for analytical tools that are used for the review. Research will continue to be needed to confirm new or unique features of near term reactor designs. In this area, research needs are at a transition point from providing design support to assisting operational oversight.

### **2.1.4 Session 3: R&D and facility infrastructure for advanced reactors (G-IV)**

*Mr. Carbonnier, Director of Nuclear Development and Innovation, CEA, France*, gave an overview of typical G-IV safety objectives. In relation to specific safety-enhancement features and safety

challenges, he referred mainly to the case of sodium fast reactors and gas fast reactors. System aspects as well as fuel and materials aspects were presented. Issues that need research include severe accident and passive safety features. The need for code validations and for material databases was also underscored.

*Mr. Kotake, Manager of Advanced Nuclear System Research, JAEA, Japan*, addressed the safety design concept for the G-IV sodium fast reactor. He observed that future licensing procedure of SFR is to reflect past experience. Considerations as to whether core disruptive accidents should be considered or not in future regulation were also given. Future research items should cover fuel behaviour, including post-accident relocation, guidelines for use of PSA and experimental evaluation of passive safety features.

*Mr. Shimakawa, Manager of Mitsubishi FBR, Japan*, focused on the safety design and related R&D issues for SFRs. In particular, he addressed the reactor shutdown, the core cooling and the containment function. Safety research will be needed to confirm these designs, e.g., passive shutdown capability, passive core cooling and elimination of re-criticality events. For this, advanced facilities will be needed, including facilities that are currently in use.

*Mr. Sheron, Director of Office of Nuclear Regulatory Research, USNRC*, provided a perspective on strategic decision on research for advanced reactors. He pointed out that advanced reactors are fundamentally different from LWRs and that regulatory tools currently available (e.g. codes and data) will not be applicable to advanced designs. He stated that international co-operation is the only practical way to work together for identifying needed capabilities and tools, including the use of industry facilities. He proposed that, in consideration of its good experience at co-ordinating research, the CSNI establishes a task group to identify and prioritise research needs.

## **2.2 Summary of the workshop chairs**

The Workshop chairs, Messrs. Repussard and Soda, summarised the presentations and discussion as follows:

### **2.2.1 Motivation for safety research**

#### *Session 1 (Operating reactors)*

- Regulatory decision making.
- Industry initiatives for plant increased efficiency.
- Plant lifetime extension (Industry goal: keep the current fleet running).
- Lessons learnt from operating experience, unforeseen behaviour or events.
- Increased use of risk informed approaches.
- Use of codes beyond their original validation database.
- Progressive sophistication of physical models.
  - Quantification of uncertainties.
  - Elicitation of expert judgment.
- Results of previous research.

#### *Session 2 (New reactors, G-III)*

- New technology to reduce human error (VR, wireless, others).
- New design features, e.g.:
  - Passive cooling features.
  - Provisions for severe accident mitigation.
- Longer design lifetime.

- Stronger concerns on security.
- More extreme environment (earthquakes, hurricanes, others).
- Improved understanding of seismic hazards for siting decisions.
- More plants in general, more plants in one site: Collective site risk.
- Research needs for new reactors are at the transition point between:  
Data to support design → Data to support operation.

*Session 3 (Advanced reactors, G-IV)*

- Need to develop regulatory tools, e.g. codes and methods.
- Understand key safety considerations, e.g. re-criticality events.
- Confirm safety design concepts.
  - Passive shutdown.
  - Passive cooling.
- Understand and predict energy release in accidental conditions.
- Understand fuel behaviour in operational and transient conditions.
- Assessment of overall core stability.
- Definition and assessment of containment function.
- Develop sufficient knowledge of material properties, interaction with radiation and coolant, material endurance.

*Motivation for research, items common to all sessions:*

- Develop consensus for closing issues that have been sufficiently investigated.
- Support harmonisation of methodologies (e.g. risk-based).
- Support maintaining competence and developing methods.
- Maintain a competent international network to support licensing.
- Preserve valuable and pro-active research facilities.

*International co-operation enables to save money and increases credibility; OECD NEA should play a major role to promote and support such co-operation through efficient project arrangements*

## **2.2.2 Main subjects of safety research**

*Session 1 (Operating reactors)*

- Plant component & materials ageing, cable ageing, diagnostics.
- Material degradation mechanisms, remedies.
- Fuel reliability, efficiency (>5% U35?), fuel behaviour anomalies.
- Fuel high burn-up safety criteria.
- Post-accident core cooling efficiency.
  - Sump clogging.
  - SG cooling efficiency.
- Post-accident core melt coolability, steam explosion.
- Human and organisational factors.
- Digital I&C reliability (CCF, spurious actuation).

*Session 2 (New reactors, G-III)*

- Confirmation of effectiveness of passive safety systems.

- Mitigating strategies for beyond design base accidents.
- Confirmation of new/ unique new design features.
- Extended use of digital I&C.
- More advanced analytical tools and methods.
- E.g. multidimensional Thermal-hydraulic codes.
- Need of validation data, hence need of facilities.
- Expanded material database.
- New fuel designs, complex assemblies, new fuel managements.
- Fuel cycles, closing the cycle.

### *Session 3 (Advanced reactors, G-IV)*

- Main subjects of safety research for SFR.
  - Severe accidents involving sodium.
  - Passive mechanisms for heat removal in accident situation.
  - Seismic aspects: core “compactation”, design remedies.
  - In-vessel retention strategies.
- Main subjects of safety research for GFR
  - High power density, small inertia, hence need of a reliable decay heat removal.
  - Refractory fuel materials, core design.
  - Ceramics with good thermal conductivity.
  - Characterisation of core materials in the 2000-3000°C range.
  - Management of severe plant situation.
  - Guidelines for PSA of advanced systems.
- Main subjects of safety research for VHTR.
  - Stochastic behaviour of pebble bed reactors.
  - Combined effects of H<sub>2</sub> co-production.
- Main common subjects.
  - Post-accident material relocation.
  - Fuel and core design.
  - Fuel materials (e.g. carbide), reliability, fuel failure resistance.
  - Guidelines for PSA of advanced systems.
  - Severe Accident approach and measures.
  - Credit for passive safety feature.
  - Materials code and standards.
  - Source term evaluation.

### **2.2.3 Organisation of research**

Regarding the organisation of research, the following main points were made:

- “The regulator should first establish its own research priorities” before determining practical means to pursue research (CSNI GRIC report).
- Consideration should be given to the transfer of results in a regulatory framework, as well as to the timeliness availability of qualified data or information.

- Specific research objectives should be pursued through international arrangements, in order where possible to facilitate harmonisation, and regulator should be associated with the planning process.
- NEA initiatives are (or should be) complementary to other international initiatives, such as those promoted by EU or IAEA.
- The NEA-CSNI projects provide an efficient way to carry out useful research and at same time keep a baseline facility infrastructure.
- These projects can support but not substitute national responsibility for maintaining competence in the safety area.
- The CSNI should assemble a Task Group to identify and prioritise and structure safety research needs in the advanced reactor area.

## 2.3 Conclusions and recommendations for the CNRA and the CSNI

### 2.3.1 *Conclusions and recommendations drawn by the CNRA Chair*

1. Need for a **focused regulatory input** (national and through international fora) into nuclear research programmes.
2. Focussed regulatory input **is necessary but not sufficient** for effective and efficient nuclear programmes, others need to input.
3. Need for effective mechanisms to ensure good co-operation and co-ordination amongst various players (national and international – e.g. CSNI).
4. Regulatory input not restricted to “rear view mirror” view but is forward looking and to stimulate new proactive thinking and maintaining a skilled workforce.
5. Lessons to be learnt from past, present and future reactors.
6. Research has to prioritise the information, when it is needed for regulatory judgement.

### 2.3.2 *Conclusions and recommendations drawn by the CSNI Chair*

1. Research supporting regulators must also be forward-looking and anticipate potential safety concerns.
2. The presentations identified specific needs for both operating and new plants. Many issues are similar for current and new plants.
3. Life extension is a key issue for today’s plants. The chance of influencing design may be important for new plants.
4. Interaction among different stakeholders is important for identifying research that can be pursued through joint arrangements.
5. Regulators research institutions and industry should promote stronger co-operation in the data gathering. Care should be taken to maintain an adequate degree of independence in the data interpretation and code development.
6. National research programs should identify priorities as well as the role of the different parties, i.e. regulators, industry and research institutions, covering an adequately long-time span.



7. Competence and infrastructure maintenance is also to be included in the regulatory evaluation of research needs.
8. The CSNI Projects are a good means for ensuring a base infrastructure and for maintaining a competence network in a practical manner.
9. There are different Gen IV designs, many non-water reactor concepts. New infrastructure will be needed to assess safety.
10. Knowledge management practices in OECD countries need to be considered.
11. International co-operation enables to save money and increases credibility; the OECD/NEA should play a major role to promote and support such co-operation through efficient project arrangements.
12. A Task Group should be set up to address the CSNI long-term strategy and approach to joint efforts for infrastructure build-up, aiming at defining:
  - Key safety and risk issues as related to specific design concepts.
  - Issues that will require experimental data.
  - Infrastructure needed for developing the required data, including key infrastructure elements, timing and roles for regulator, research institutions and industry.



### **3. PRESENTATIONS**

#### **OPENING SESSION**

#### **CHANGES AND CSNI/CNRA ACHIEVEMENTS SINCE 2001**



**NEW PERSPECTIVE AND R&D CHALLENGES REGARDING  
THE SAFE DEVELOPMENT AND USE OF NUCLEAR ENERGY**

**Dr. Kunihisa Soda**

*Commissioner, Nuclear Safety Commission, Japan*

## **The Role of Research**

---

- To provide scientific and technical basis needed for the decision-making by the regulatory bodies and the basis should be updated to meet the latest development of technology.

---

RRRC-II/Paris/NSC(KS)

## The Recommendations of RRRC-I

---

- The recommendations are still valid and valuable for research in a regulatory context and to be included in new recommendations for the safe development and use of nuclear energy.
  - *Research capability must be maintained such as experimental facilities, expertise, knowledge base etc.*
  - *Realistic regulation decision for operating, advanced and future types of reactors.*
  - *Stakeholder involvement was recommended with consideration given to transparency.*
  - *Research should be reviewed internationally*

---

RRRC-II/Paris/NSC(KS)

## Changes Since RRRC-I

---

- Construction of new nuclear power plants have restarted in the countries where construction was halted for long time after the TMI-2 and Chernobyl accidents.
- Nuclear industry has become global as the results of establishment of new organizations, new collaboration among corporations, or creating new entities.
  - *The globalization may need the global or internationally harmonized safety standard for new nuclear reactors.*
- New technologies have been developed and applied to operation of nuclear reactors such as new materials, operation and maintenance technology including digital system and risk based information etc.

---

RRRC-II/Paris/NSC(KS)

## **New Perspective and R&D Challenges *Existing Reactors***

---

- Nuclear safety research has been focused on mainly to identify and resolve safety issues.
- Knowledge base has been expanded and accumulated to the extent that safety of nuclear reactors has been much improved.
- Lessons learned from R&D for existing reactors should be applied to design and construction of new reactors.

---

RRRC-II/Paris/NSC(KS)

## **New Perspective and R&D Challenges *Next Generation Reactors***

---

- Integrated approach for ensuring safety in all processes of design, construction, operation and maintenance is taken into consideration.
- R&D may contribute to the regulatory needs.
  - *Use of risk information, development of advanced analysis method, new construction technology, total efficiency upgrade, well balanced system design, in-service inspection and maintenance procedure, external events etc.*

---

RRRC-II/Paris/NSC(KS)

## **New Perspective and R&D Challenges *Future Reactors***

---

- Needs for future reactors come from various view points ranging from efficient use of nuclear energy, fuel cycle including breeding, inherent safety etc.
- The basic safety principle for future reactors is the same as existing and new reactors to prevent any abnormal occurrence and accidents leading to serious consequences to the public and the environment.
- Safety research should be aimed at improving and confirming safety to make future nuclear reactors acceptable by the general public with advanced technology.

---

RRRC-II/Paris/NSC(KS)

## **Summary**

---

- Nuclear safety research has provided scientific and technological background for the regulatory decision-making and should continue the same role for existing, next generation and future reactors.
- Knowledge base and expertise developed in the past years should be incorporated into development of next generation and future reactors.

---

RRRC-II/Paris/NSC(KS)



**CSNI INITIATIVES AND LESSONS LEARNED THAT CAN BE BROUGHT FORWARD  
IN THE FUTURE: EXPECTATIONS ARISING FROM NUCLEAR RENAISSANCE**

**Mr. Jacques Repussard**  
*Director General, IRSN, France*

**6 years ago: the CSNI RRC 2001 context**

- | **Challenge:** Preservation of key nuclear safety knowledge, competencies and infrastructures disciplines and actions aimed at sustaining and experimental facilities, in a context of reduced resources and uncertain energy policy models.
  
- | **Initiatives:**
  - Setting up of international NEA projects in safety areas such as thermal-hydraulics, severe accidents, fuel safety...
  - Participation to the creation of international funded programmes centred on selected experimental facilities
  - Development of NEA databases
  - In favour of the launching of centres of excellence

**IRSN**

## **NEA initiatives in response to the 2001 recommendations have been successful:**

- ‡ They helped enrich existing NEA WG activities
- ‡ They facilitated multinational co-operation (TSOs, industry...)
- ‡ They produced safety relevant data and tools, contributing to the resolution of specific safety issues
- ‡ They led to international analytical exercises through test code simulations of selected experiments from NEA programmes
- ‡ They prevented the untimely closure of unique facilities necessary to maintain a sufficient nuclear safety experimental infrastructure
- ‡ They helped transferring nuclear safety knowledge to the younger generation

**IRSN**

## **As a result, the nuclear safety R&D community has remained fit to address today's challenges:**

- ‡ **Review the safety of existing GEN II reactors until their closure (ageing, agressions, fuel safety criteria)**
- ‡ **License GEN III (and II+) reactors in a new economic and international context**
- ‡ **Upgrade emergency preparedness in line with existing scientific knowledge and societal expectations**
- ‡ **Assess geological waste repository projects**
- ‡ **Contribute to generic safety and security features of future GEN IV reactors**

Joint CNRA/CSNI Workshop, "The Role of Research in a Regulatory Context", Paris December 5th, 2007

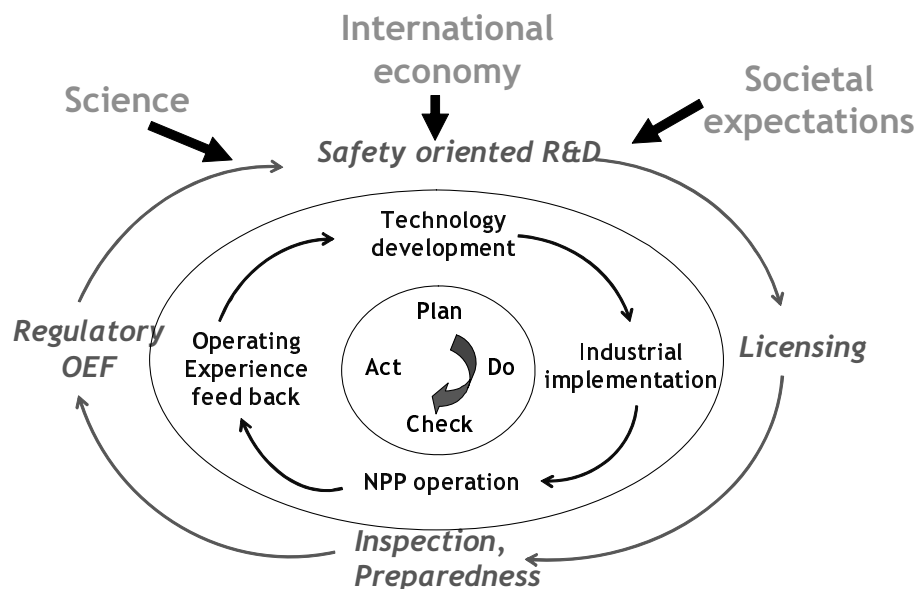
**IRSN**

## Towards a new roadmap for CSNI and nuclear safety R&D

- ! *More data, robust codes, agreed criteria, open experimental and expert training facilities (simulators, ...) will be needed:*
- Develop linkage to fundamental science developments (maths,...), and to R&D in comparable sectors (aeronautics, ...)
- Develop and promote medium and long term R&D plans, including infrastructure, human resource, economic, and multinational regulatory aspects
- Organize open dialogue with all key stakeholders: parliaments, regulators, industry, NGO's
- Facilitate pooling of reference expertise

Joint CNRA/CSNI Workshop, "The Role of Research in a Regulatory Context", Paris December 5th, 2007

IRSN



Take into account a holistic view of targets, in their context, so that R&D responds in timely manner

IRSN



**SESSION 1**

**RESEARCH NEEDS AND FACILITY UTILISATION FOR OPERATING REACTORS**



**RESEARCH, A KEY FOR IMPROVING NUCLEAR SAFETY  
AND RADIATION PROTECTION: A REGULATOR VIEWPOINT**

**Ms. Marie-Pierre Comets**  
*Commissionner, ASN, France*



## Outline

- 1- Introduction
- 2- The role of safety authorities in the research field
- 3- The international practices
- 4- What ASN expects from the research centers
- 5- Examples of research issues
- 6- Conclusion



## 1- Introduction

Research in nuclear safety and radioprotection covers a broad and varied field.

Nuclear safety authorities:

Decision making ← expertise ← research



## 2- The role of safety authorities in the research field

Safety authorities:

- need the results of research for decision making, regulating and controlling
  - are final users of the research programs
  - must make sure their needs are taken into account
- ⇒ express an opinion on public research programs (aims, priorities)
- ⇒ be informed of program progress and results.





### 3- International practices

- Recommendation of the IAEA IRRS mission (Integrated Regulatory Review Service) at ASN in November 2006:  
"ASN should consider development of its input into and formal monitoring of research and development in nuclear and radiation service"
- Safety authorities are involved in the definition of the research programs (STUK, CSN, NRC...)



### 4- What ASN expects from the research centers:

In France, many participants involved in the research programs : IRSN, research bodies (CEA, CNRS, INSERM), universities, engineering schools and licensees (EDF, AREVA, ANDRA).

ASN expects from the operators:

- to carry out research (flooding risk)
- its own requests to be inputs (generation IV reactors)

ASN expects from IRSN research fitted to control needs.

Good overall coordination required.



## 5- EXAMPLES of research issues

- ✓ chemical phenomena in sump filter clogging
- ✓ issues in human and organisational factors
  
- ✓ material ageing
- ✓ fuels at high burn-up rates
- ✓ steam explosion conditions in case of water flooding of the reactor vessel pit
- ✓ ....

Importance of experimental facilities.



## 6- Conclusion

- Importance for safety authorities to be involved in research
  
  - ASN will express its opinion on the objectives of the public research programs in nuclear safety and radiation protection
  - ASN will be kept informed of the results of these programs
  - ASN will thus be in line with international practices
- Regular meetings of all the participants necessary to share information and optimize the means.

**SELECTION AND PRIORITISATION OF SAFETY RESEARCH PROJECTS FOR  
EXISTING REACTORS: A NEW REGULATORY APPROACH IN JAPAN**

**Dr. Kiyoharu Abe**  
*Technical Counsellor, JNES, Japan*

## **1. Introduction**

- In Japan, governmental nuclear safety research is defined as “research for contributing to regulation”.
- Results of research must be used for :
  - Development or revision of regulatory codes & standards (C&S),
  - Resolution of regulatory issues, or
  - Regulatory decision-making.
- This presentation is for introducing a NISA’s new approach initiated in 2006, which aimed at reasonable selection and prioritization of safety research projects.

## **2. Overview**

### **2.1 Overall Idea and Advisory Subcommittee**

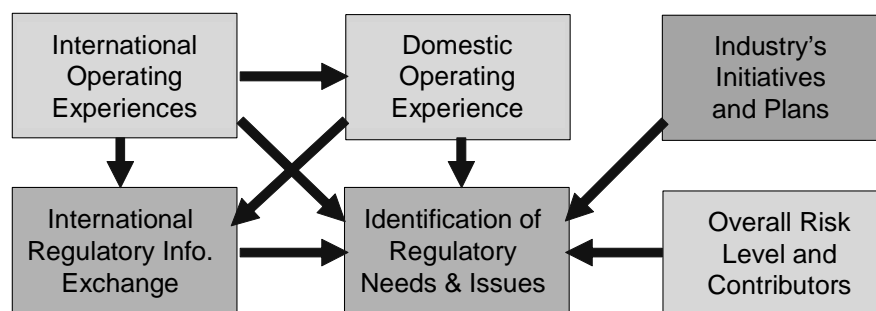
- Overall idea of the approach is illustrated in Fig. 1.
- NISA established the “Subcommittee (SC) on Nuclear Safety Infrastructure” under the “Advisory Committee on Nuclear and Industrial Safety”.
- The SC consists of members from industry, academic societies, experts from various areas, etc. with JNES and JAEA as observers.
- The SC discusses how NISA should preserve knowledge, competent experts, research programs, experimental facilities and C&S development activities, all of which are necessary for regulation, by keeping collaboration among participating organizations.

### **2.2 Roles of Participating Organizations**

- NISA identifies regulatory needs and issues.
- Academia develops consensus standards as well as long term plans (roadmaps) to develop them (C&S-RMs).
- Academia also develops roadmaps for safety research (R&D-RMs), referring the schedule for standards development defined by C&S-RMs.
- NISA and SC examine the adequacy of these RMs and endorse them.
- NISA and JNES propose the research projects according to the R&D-RMs.
- SC examines the adequacy of the research results.

### 3. Identification of Regulatory Needs & Issues - Where do Regulatory Needs Arise from? -

- Industry-side initiatives and plans
- Operational experiences in Japan and other countries
- Risk information obtained as PSA results
- Results of safety research



#### 3.1 Consideration of Industry's Initiatives and Plans in Identifying Research Needs

Industry's Initiatives and Plans	Regulatory Responses	Research Needs
Life extension of existing reactors	Examination of licensees' ageing management technology	R&D-RM for ageing management, incl. SCC data acquisition.
Utilization of fuel to higher burn-up and introduction of MOX fuel	Licensing criteria & regulatory decision on usage of such fuel	R&D-RM for fuel safety, incl. research on fuel behavior under LOCA and RIA conditions

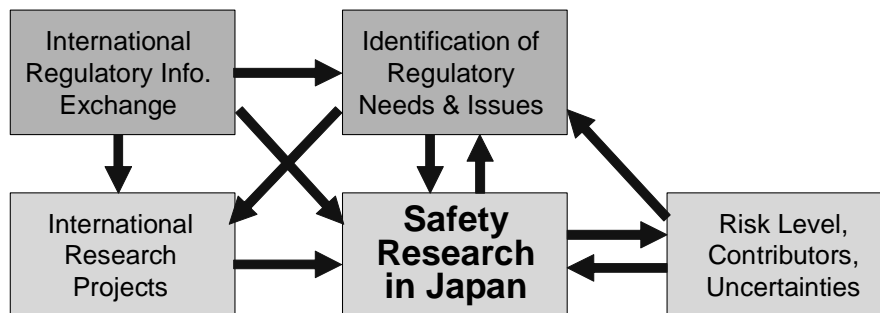
Remarks: R&D-RMs were already developed for ageing management and fuel safety. R&D-RMs are under development or expected to be developed for thermal-hydraulics, seismic safety, fuel cycle safety, etc.

### 3.2 Operational Experience Feedback to Regulation and Research Needs

Operational Experience	Regulatory Responses	Research Needs
Mihama accident <ul style="list-style-type: none"> <li>▪ Aged piping failure</li> <li>▪ Steam leaking into control room</li> <li>▪ Degraded safety culture</li> </ul>	<ul style="list-style-type: none"> <li>▪ Evaluation of ageing management technology</li> <li>▪ Examination of control room habitability</li> <li>▪ Root cause analysis in inspection program</li> </ul>	<ul style="list-style-type: none"> <li>▪ Comprehensive ageing research (with SCAP)</li> <li>▪ Perhaps, intl. common topic</li> <li>▪ Human/organizational factor research</li> </ul>
Sump clogging (Old issue but importance revisited)	Regulatory order for changing sump design, when needed	Chemical effect test by JNES
Cracks of BWR control rods with hafnium blades	Regulatory order requesting more reliable control rods	Additional IASCC research at JAEA/JMTR facility
Seismic effects at Kashiwazaki-Kariwa	Examination of seismic safety of plants, etc.	More comprehensive seismic safety research

### 4. Selection and Prioritization of Research

- R&D-RMs are developed for regulatory needs and issues as well as industry needs.
- Adequate coordination is sought among regulatory research, industry safety research, and international projects.
- Priorities are given and schedules are determined.
- Review process for R&D-RMs and plans and results of research projects is shown in Figure 2.



#### **4.1 Example of R&D-Roadmap Development: Ageing Management**

- Background: Increase of aged plants and Mihama accident in 2004.
- Regulatory action: Evaluation of licensees' ageing management technology, with support by JNES.
- R&D-RM for ageing management:
  - Identifies research needs to resolve issues,
  - Seeks to provide information bases, and
  - Must be revised periodically reflecting most up-to-date knowledge.
- International collaboration: To establish common database, e.g. through SCAP.

#### **4.2 Research by Industry and NISA**

- Industry
  - Research to maintain and improve safety and reliability of facilities and activities.
  - Research for developing industrial standards.
  - Research to demonstrate integrity of SSCs and adequacy of operation and maintenance, in response to NISA's regulatory requirements.
- NISA
  - Research to develop and revise regulatory frameworks or requirements or to provide adequate bases for making regulatory decisions.
  - Research to maintain and upgrade technical knowledge & competence needed for regulation.

### **4.3 Coordination between International Research Projects and National Research Programs**

- Japan is being a member of many OECD projects and IAEA/CRPs.
- Japan is hosting OECD-ROSA Project and has proposed OECD-SCAP Project.
- Japan keeps being an active member in OECD projects and promoting international collaboration.
- Japan concurrently preserves necessary research activities and facilities within the country in order to avoid loss of competence.
- If domestic research activities decline excessively, Japan loses an ability to understand and utilize results from international projects.

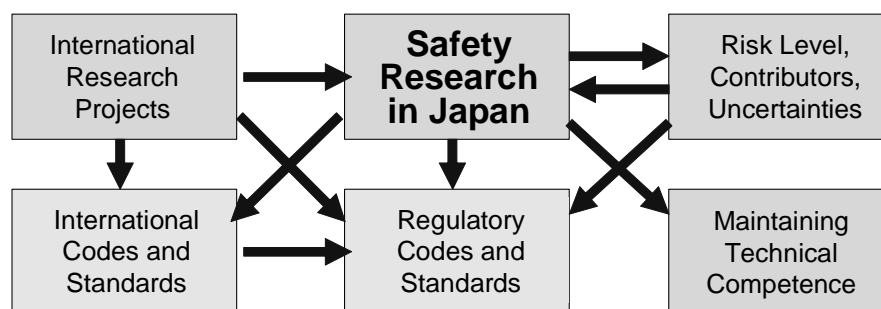
### **4.4 Preservation of Key Experimental Facilities**

- Preservation of safety research facilities is internationally common issue.
- In most member states, however, it becomes more and more difficult due to shrinking budget.
- Discussions in NEA:
  - 2003:GRIC report
  - 1992~2007:CSNI/SESAR activities
- NISA's criteria to preserve facilities:
  - Facilities to resolve issues defined in R&D-RMs.
  - Facilities important from the aspect for international projects.
  - Performance, cost/benefit, rationality to maintain domestically, contribution to competence, etc. are taken into account.



## 5. Outcomes of Research

- Codes & standards
- Information to resolve regulatory issues
- Information utilized for regulatory decision-making
- Updated risk profile
- Maintaining key technical competence



### 5.1 Utilization of Consensus Standards in Regulation

- In the past, NISA's "Technical Requirements" contained safety performance requirements as well as detailed specifications to satisfy them, although different approaches could be accepted.
- Now, NISA's requirements are only on safety performance. Approaches to satisfy them are to be specified in "Consensus Standards" developed by academia.
- Academic societies established committees to develop consensus standards.
- Review process for C&S-RMs and codes and standards is shown in Figure 3.

## 5.2 Reflection of Outcomes of R&D, PSA and Peer Reviews to Regulation and Further R&D Needs

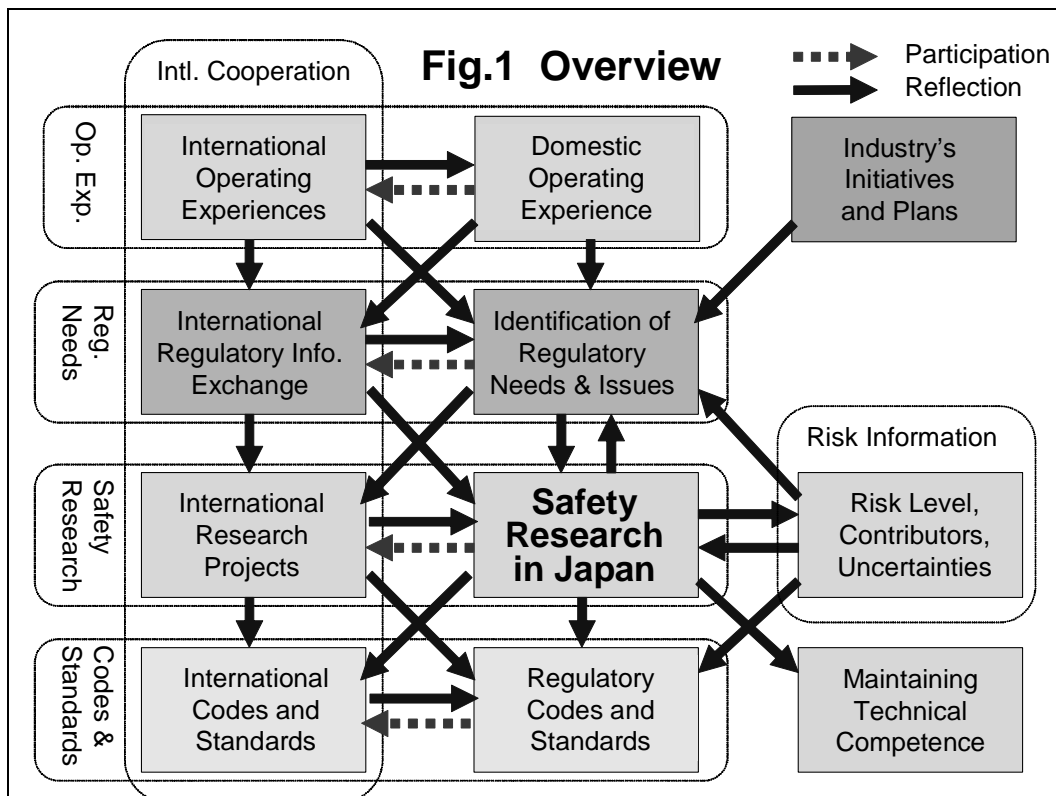
Outcomes of R&D, PSA & Peer Reviews	Regulatory Responses	Further Research Needs
Recent knowledge on seismology as well as evaluated large seismic risks	Revision of seismic design review guide by NSC and reassessment of seismic safety of existing plants by licensees & NISA	Perhaps more comprehensive seismic safety research programs
Weakness of aged cable under LOCA conditions	Regulatory order to examine integrity of aged cable	Already Intl. common research topic in SCAP
2004 IAEA/OSART to Kashiwazaki-Kariwa	Revision of C&S for fire protection	Fire PSA by JNES and participation in OECD fire projects
2007 IAEA/IRRS to NISA	To be considered	To be considered

## 6. Concluding Statement

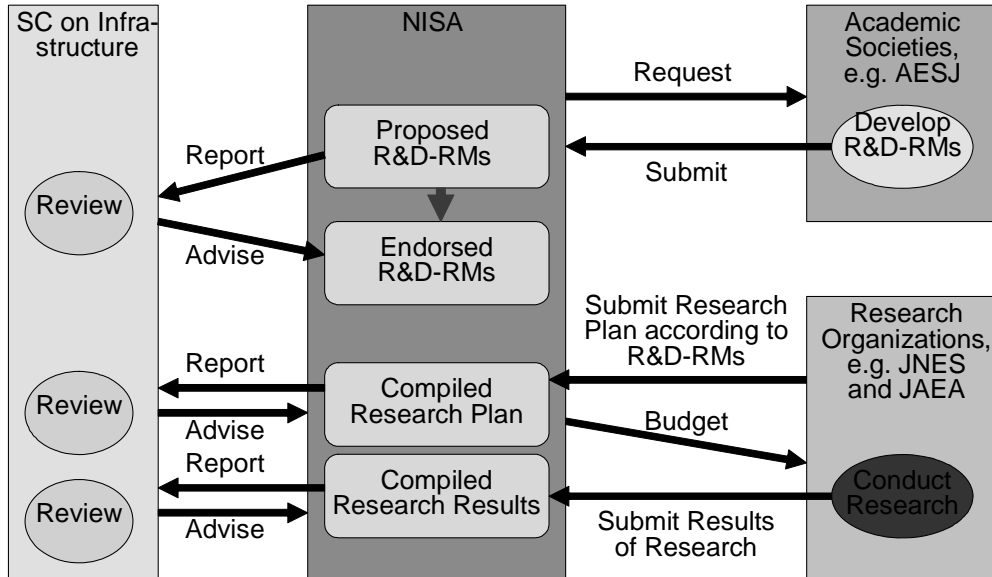
- CNRA & CSNI jointly discussed how safety research, including OECD projects as well as national projects by member states, should contribute to nuclear regulation.
- RRRC & RRRC-II are in this context.
- In the very same context, NISA newly adopted an approach to select and prioritize safety research projects.
- For this purpose, NISA established the “Subcommittee on Nuclear Safety Infrastructure”.

## 6. Concluding Statement (Cont.)

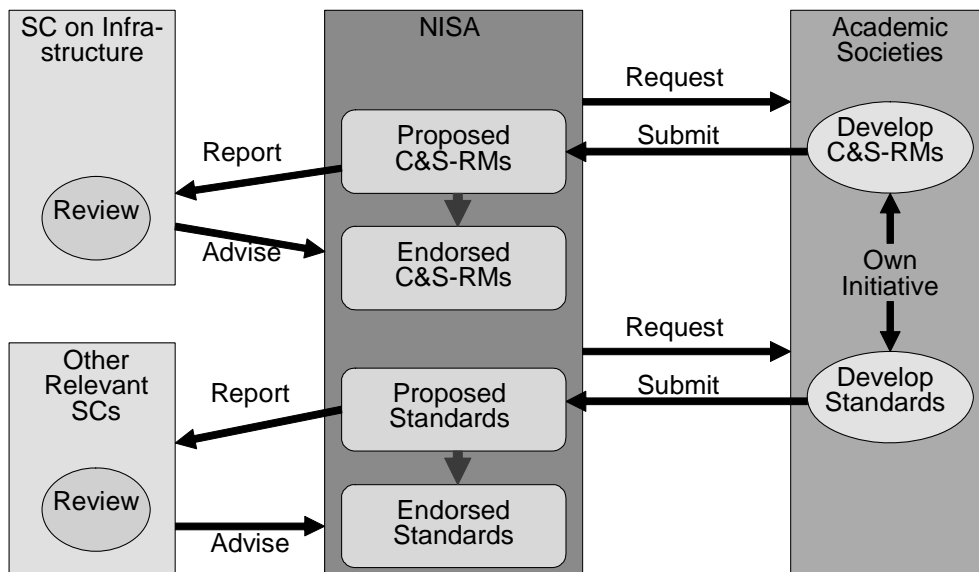
- With this new approach, NISA:
  - Introduced external review process for budget and outcomes of safety research projects,
  - Established strategy (1) to carry out safety research, (2) to develop/revise codes & standards, and (3) to establish more effective and efficient regulation,
  - Developing R&D-RMs and C&S-RMs,
  - Trying to have better collaboration with industry and academia to conduct safety research and to develop/revise consensus standards, and
  - Showed its strong intention to preserve knowledge, competent experts, research programs, experimental facilities and C&S development activities.



**Fig.2 Process to Develop and Endorse R&D-RMs and to Review Plans and Results of Research**

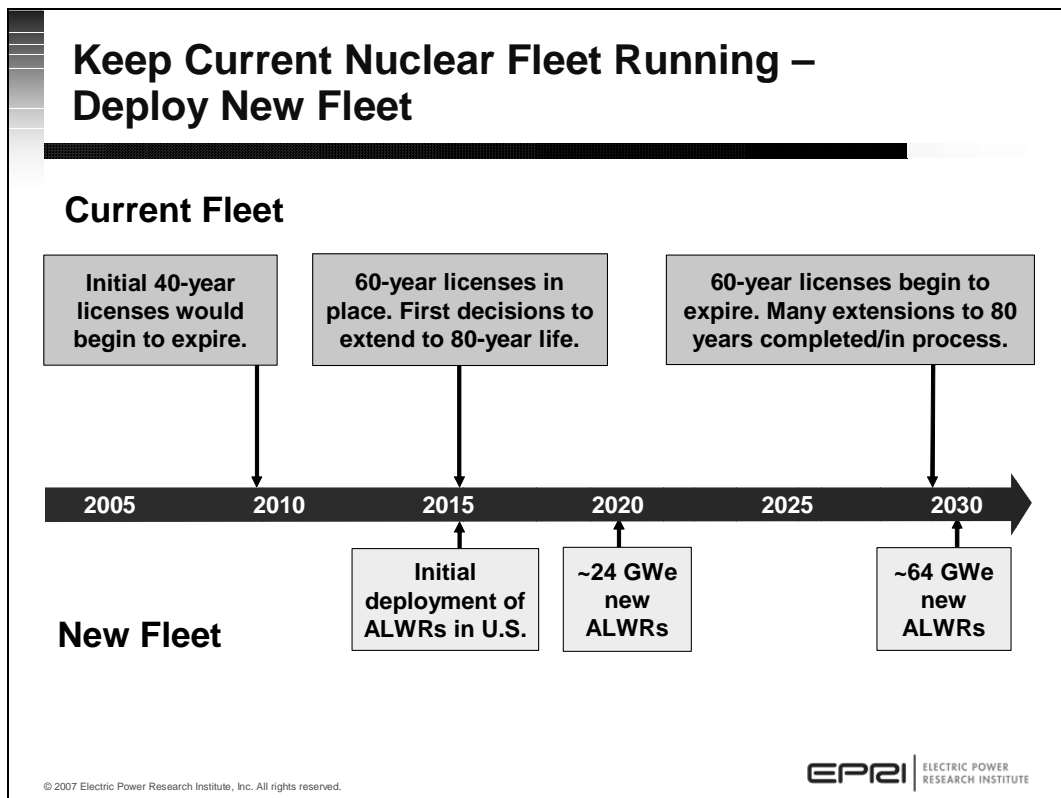


**Fig.3 C&S-Roadmaps and Process to Endorse Consensus Standards**



## INDUSTRY PERSPECTIVE ON R&D NEEDS

**Dr. Rosa Yang**  
*Vice-President, EPRI, United States*



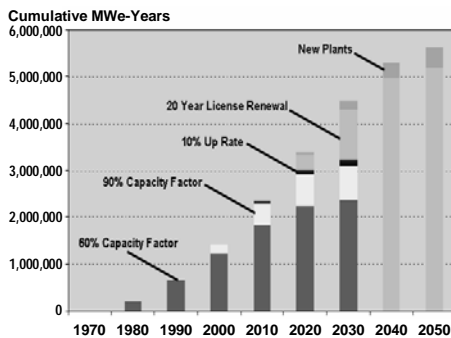
## Technology Required to Maximize Current Fleet Longevity & Performance

### Assumption & Necessity

- Sustained safe, reliable, economic operation
- Extended lifetimes – well beyond 60 years



### U.S. Nuclear Generation



### R&D Required

- Materials degradation
- Fuel performance
- Digital I&C technology
- Cable diagnostics and alternative replacements

© 2007 Electric Power Research Institute, Inc. All rights reserved.

**EPR** | ELECTRIC POWER RESEARCH INSTITUTE

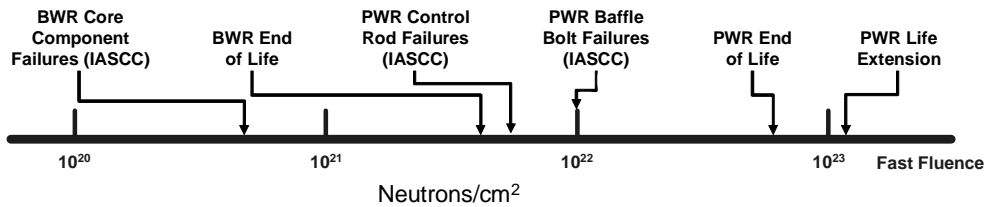
## Material Degradation is Limiting Plant Performance

- Two major degradation mechanisms for LWRs:
  - Environmentally Assisted Cracking (*EAC*) of Pressure Boundary Components
    - PWSCC
    - IGSCC
  - Irradiation-Assisted Stress Corrosion Cracking (*IASCC*) of Internals
- Propensity for degradation has been evaluated and documented in the Materials Degradation matrix

© 2007 Electric Power Research Institute, Inc. All rights reserved.

**EPR** | ELECTRIC POWER RESEARCH INSTITUTE

## IASCC is Important for Current LWRs & Life Extension



- All materials will crack at some point; it is important to know when, where and what to do about them
  - ✓ Prediction
  - ✓ Inspection
  - ✓ Mitigation
  - ✓ Repair and replace

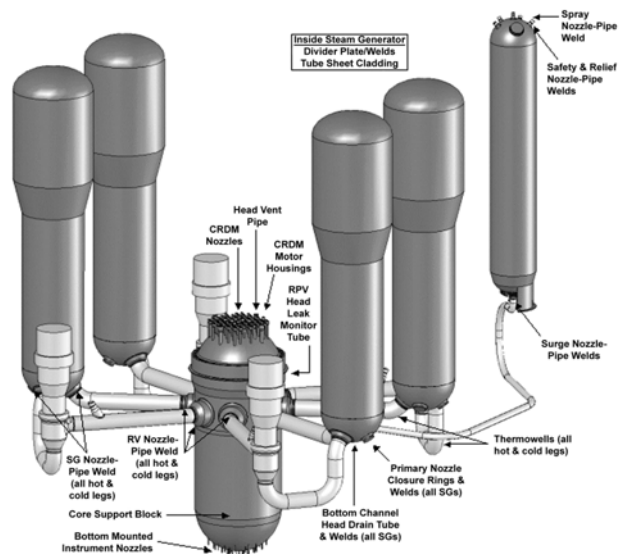
© 2007 Electric Power Research Institute, Inc. All rights reserved.

**EPRI** | ELECTRIC POWER RESEARCH INSTITUTE

## Crackings in PWR Components – PWSCC

Environmentally Assisted Cracking (*EAC*) of Pressure Boundary Components

Cracks occur at base metal, Welds and heat affected zones

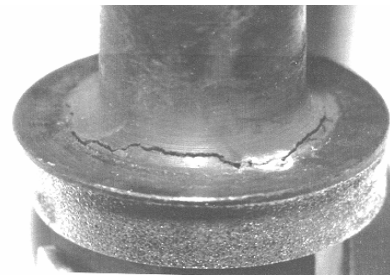
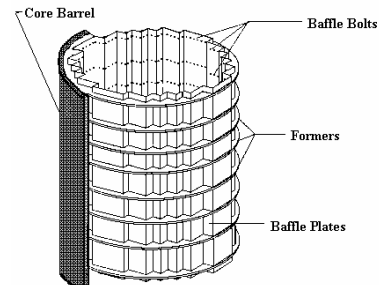


© 2007 Electric Power Research Institute, Inc. All rights reserved.

**EPRI** | ELECTRIC POWER RESEARCH INSTITUTE

## IASCC of PWR Internals

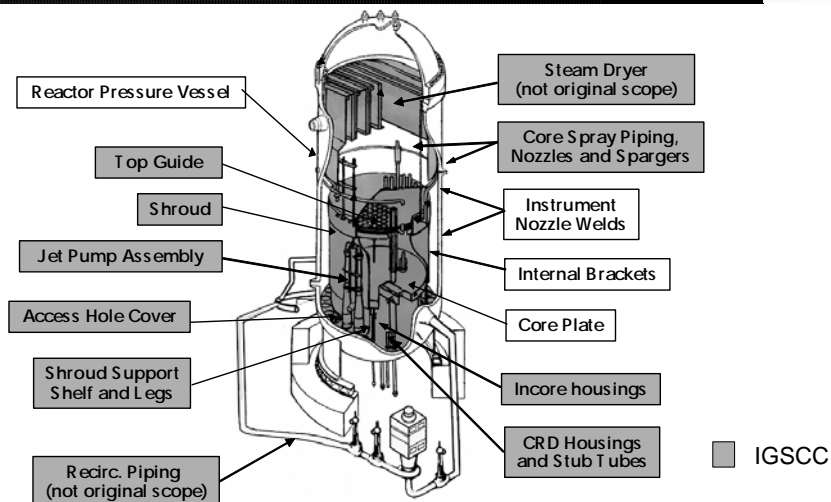
- Irradiation-Assisted Stress Corrosion Cracking (*IASCC*) of internal components
- Baffle bolt cracking
- **Other** internal components in high fluence regions are susceptible to IASCC
- Other radiation-assisted damage mechanisms can occur



© 2007 Electric Power Research Institute, Inc. All rights reserved.

EPRI | ELECTRIC POWER RESEARCH INSTITUTE

## R&D to Manage IGSCC & IASCC in BWRs



Comprehensive Approach to Mitigation, Inspection, Assessment, and Repair for All Internals

© 2007 Electric Power Research Institute, Inc. All rights reserved.

EPRI | ELECTRIC POWER RESEARCH INSTITUTE



## R&D Needs for Advanced NDE

- Improved remote visual examination
- Aging plant NDE
- Stainless steel in PWRs
- Filmless radiography
- NDE workforce



© 2007 Electric Power Research Institute, Inc. All rights reserved.

**EPRI** | ELECTRIC POWER  
RESEARCH INSTITUTE

## R&D Needs for Fuel

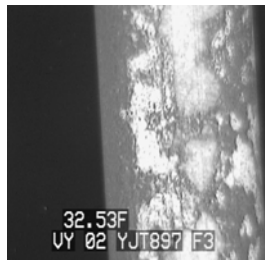
- Improved fuel reliability
  - Prediction capabilities
    - Data and model
  - Better understanding and quantifications of the interactions of fuel materials, operation and water chemistry
- Safety criteria at high burnup
  - RIA and LOCA
- Beyond 5% enrichment

© 2007 Electric Power Research Institute, Inc. All rights reserved.

**EPRI** | ELECTRIC POWER  
RESEARCH INSTITUTE

## Codes are NOT Adequately Addressing Local Conditions

- Fuel is increasingly being operated well beyond the domain over which core physics, neutronics and T/H codes have been validated
  - Fuel performance monitoring and failures indicate local anomalies



© 2007 Electric Power Research Institute, Inc. All rights reserved.

**EPRI** | ELECTRIC POWER RESEARCH INSTITUTE

## Complex Fuel Assembly Design

- Complicated assembly designs and operating conditions present a challenge to codes

	A	B	C	D	E	F	G	H	I
1	2.00	2.80	3.60	3.95	4.40	3.95	3.95	3.20	2.80
2	2.80	3.95	4.40	4.40 6.00	4.90	4.90	4.90	4.90	3.60
3	3.60	4.40	4.40 6.00	4.90	4.40 6.00	4.90	4.40 6.00	4.90	4.40
4	3.95	4.40 6.00	4.90	4.90	WR	-	4.90	4.40 6.00	4.90
5	4.40	4.90	4.40 6.00	WR	-	-	4.40 6.00	4.90	4.90
6	3.95	4.90	4.90	-	-	4.90	4.90	4.40 6.00	4.90
7	3.95	4.90	4.40 6.00	4.90	4.40 6.00	4.90	4.90	4.90	4.90
8	3.20	4.90	4.90	4.40 6.00	4.90	4.40 6.00	4.90	4.90	3.95
9	2.80	3.60	4.40	4.90	4.90	4.90	4.90	3.95	3.20

- Enrichment variation
- Higher Gd, axial zones
- Part length rod

© 2007 Electric Power Research Institute, Inc. All rights reserved.

**EPRI** | ELECTRIC POWER RESEARCH INSTITUTE

## Burnup Extension Study

- Significant cost savings (on an industry-wide basis) and reduced spent fuel inventory by moving to 62 GWD/T
  - \$175 M/yr for fleet of U.S. PWRs
  - \$50 M/yr for fleet of U.S. BWRs
  - Increased savings continue beyond 62 GWD/T
- Benefits can offset the one-time costs of upgrading enrichment and transportation capabilities (estimated at \$75 M - \$100 M)

© 2007 Electric Power Research Institute, Inc. All rights reserved.

**EPRI** | ELECTRIC POWER  
RESEARCH INSTITUTE

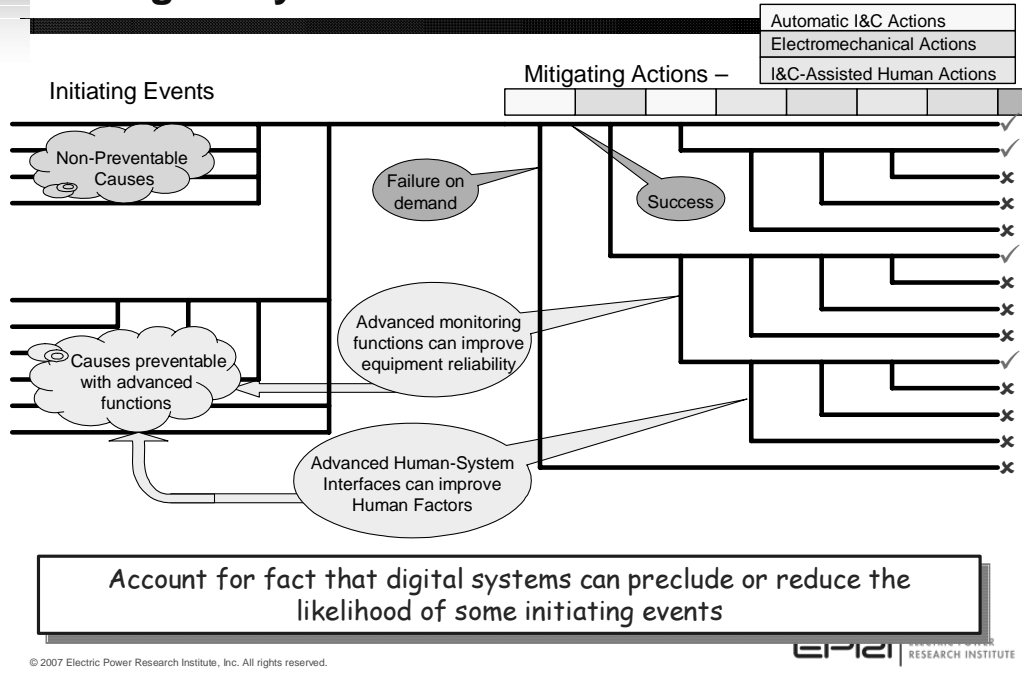
## Instrumentation & Control

- Objective: Establish methods that allow digital system decisions based on overall impact on plant safety
- Technical Issues:
  1. Represent digital systems failures
    - Causes – hardware, software, human factors ...
    - Effects – spurious actuation, failure to actuate, common-cause failures (CCF) ...
  2. Estimate digital system probability of failure, CCF
    - Currently, no generally consensus method for highly reliable digital systems
  3. Exploit safety benefits of digital systems
    - Advanced functions improve reliability, reduce scope of human errors, improve ability to cope with incidents, etc.
    - Use realistic assumptions to guide I&C decisions

© 2007 Electric Power Research Institute, Inc. All rights reserved.

**EPRI** | ELECTRIC POWER  
RESEARCH INSTITUTE

## “Extended” Event Tree Shows Overall Impact of Digital Systems



## What Combination of Digital Process & Design Attributes is Adequate for Safety?

- Should not overemphasize process attributes
  - Tenuous connection to safety, dependability
  - Diverse backups still needed to deal with uncertainties
- Should also consider design features and actual behaviors
  - More compelling evidence of safety, dependability
  - Allow consideration of plant and digital system characteristics that protect against digital failure and digital CCF, e.g.,
    - Data validation
    - Procedures that allow changes to only one channel at a time
    - Operating system “blind” to plant transients
- Should relate specific design and process attributes to “reasonable assurance”
  - What is necessary, sufficient, desirable, etc.
  - “Piping code” type approach for digital in nuclear safety applications

## Summary

- To reduce greenhouse effects, it's critical to keep the current fleet running safely and reliably for 60+ years
- Key R & D needs for current fleet and license renewal have been identified:
  - Materials degradation
  - Fuel performance
  - Digital I&C technology
  - Cable diagnostics and alternative replacements



## **ORGANISATION OF SAFETY RESEARCH PROGRAMMES AND INFRASTRUCTURE FOR EXISTING REACTORS**

**Dr. Jean Claude Micaelli**  
*IRSN, France*

### *Context and concerns*

**Does the excellent performance record of existing installations mean that we know enough and that a high level of safety can be kept even with reduced research efforts?**

**Costs of large programmes are generally shared in the frame of international programmes, could we integrate further the international R&D efforts and optimize the use of available means?**

**How to preserve the acquired knowledge/competence and existing large/unique infrastructures?**

## *Outline*

Driving forces for Safety Research

Research and development features

Advanced analytical capabilities

Infrastructures

Capitalising knowledge

International Cooperation

Summary and Conclusions

## *Driving Forces for Safety Research*

**Operating experience feedback, e. g.**

Degradation of steam generator pipes

**Evolution of operating modes, e.g.**

Aging, high burn up

**New technologies, e. g.**

Digital instrumentation and control (I&C)

**Advanced methodologies, e.g.**

Multi-scale modelling

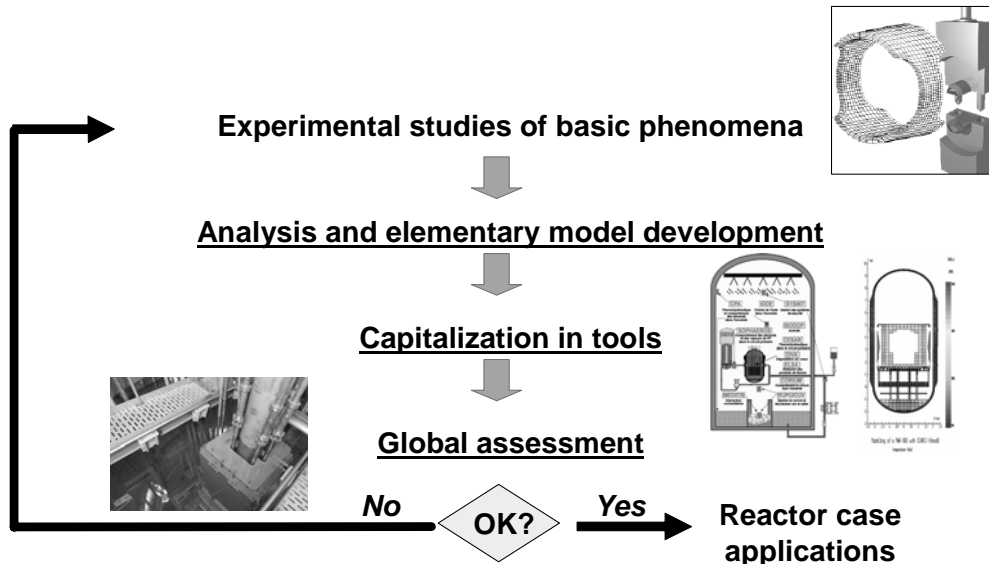
**Research itself yields findings which motivate additional investigations, e. g.**

PHEBUS FP experiments showed unexpected behaviour of iodine.

**Challenging research is an excellent means to preserve know-how and professional skills.**



## Knowledge Acquisition Methodology



The Role of Research in a Regulatory Context, Joint CNRA-CSNI Meeting, Paris, 5 December 2007

IRSN

## Advanced analytical capabilities

### Modelling progress

- Progressive sophistication of physical models, e.g.
  - Thermo-hydraulic: from homogeneous to multi-field models
- Multi-physics coupling, e.g.
  - Neutronic-thermo-hydraulic-fuel for power excursion transient
- Advanced detailed numerical simulation (multi-scale)
  - To back the elaboration of well grounded macroscopic models
  - To replace macroscopic simulations

### Impact on research activities and methodologies

- Will reinforce the need of uncertainties quantification
  - Well assessed propagation methods to account for epistemic/random uncertainties
- Will modify the balance between separate effect experimentation and integral experimentation

The Role of Research in a Regulatory Context, Joint CNRA-CSNI Meeting, Paris, 5 December 2007

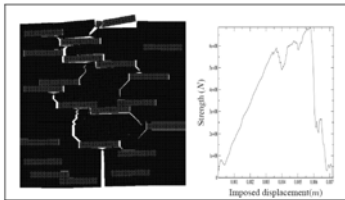
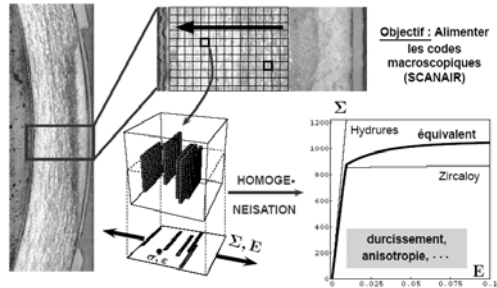
IRSN

## Fuel behaviour, multi-scale approach

- Advanced Simulation: Modelling and numerical simulation of onset and growth of cracks in irradiated fuel cladding during a RIA

### Deriving an equivalent behaviour law

- Local behaviour
- $Zr_4$  matrix with hydride platelets



### Irradiated cladding failure criteria

- Fracture mechanics not applicable
- Understand the mechanisms responsible for onset and growth of cracks
- Cladding failure predictive criteria
- 3D thermo-mechanical simulation
- Experiments:
  - ⇒ Determine local behaviour of each phase
  - ⇒ Determine micro et meso structural phenomena

The Role of Research in a Regulatory Context, Joint CNRA-CSNI Meeting, Paris, 5 December 2007

IRSN

## Maintaining Experimental Infrastructures

Experiments provide the data base for model development and code validation.

International efforts are necessary to maintain the experimental infrastructures for safety research. OECD/NEA projects are an efficient mean to support this objective.

An updated OECD/NEA report (SESAR/SFEAR) has issued recommendations for short-term and medium-term actions.

Several OECD/NEA projects contributed to maintaining these infrastructures while providing useful experimental results, e.g.

PKL, ROSA, MACE, RASPLAV/MASCA, ...

The Role of Research in a Regulatory Context, Joint CNRA-CSNI Meeting, Paris, 5 December 2007

IRSN

## Large Experimental Infrastructures



### PKL test facility at AREVA in Erlangen.

Model of 1300 MW PWR, 4 Loops, primary/secondary side, Volume-/Power-scale 1:145, Height 1:1

Objectives: Investigation of thermal-hydraulic system behaviour during transients and accidents, database for code validation, training of NPP staff, response to current and upcoming safety issues

Recently involved in two OECD/NEA projects

### PHEBUS reactor at CEA in Cadarache

Pool type reactor, ~ 1800 UO<sub>2</sub> rods - fissile length 80 cm  
Maximum core power ~ 40 MW

3 programmes:

Phébus-LOCA: Study of Design Basis Accidents

Phébus-CSD: Study of Fuel Degradation (SA)

Phébus-FP: Integral Simulation of a Severe Accident



An International Expert Group has issued recommendations on potential future use of that unique nuclear facility. But...

The Role of Research in a Regulatory Context, Joint CNRA-CSNI Meeting, Paris, 5 December 2007

IRSN

## Capitalising Knowledge

### Two types of means:

Codes that assembles all the acquired knowledge and understanding of phenomena under ready to use form, e.g.

- System codes such as TRACE, CATHARE, ATHLET, ... in the thermal-hydraulic domain; MELCOR, ASTEC, ... in the SA domain; FRAPTRAN, SCANAIR, ... for fuel safety

Database in which are stored, experimental results and/or synthesis reports (SOAR, ...)

- Two types of database: centralized, e.g. OECD/NEA, or distributed (database network), e.g. DATANET for SARNET

Beyond its capitalization the information shall be rapidly available, it means that :

#### Codes:

- Competent people shall be mobilized around codes: developments, assessment and training actions shall be pursued

#### Data bases:

- Shall be well structured and contain synthetic information
- Could be in the future supplemented by expert systems that will help safety experts to analyse cases

The Role of Research in a Regulatory Context, Joint CNRA-CSNI Meeting, Paris, 5 December 2007

IRSN

## *Integrating Research Internationally*

**Maintaining complete coverage of all safety-relevant areas by research activities requires a sustainable form of cooperation.**

**A promising example in tackling the fragmentation that exists between the different R&D national programmes was the launching of SARNET.**

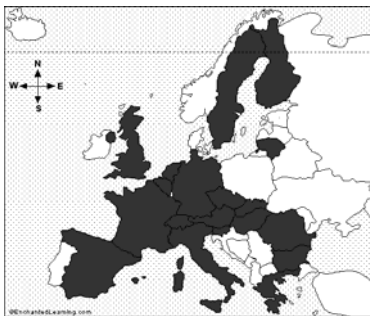
- This Network of Excellence established with support from the EC under the 6th FP is about to integrate severe accident research in a sustainable manner.

**One may also mention ETSON, one the objects of this TSO network will deal with a better integration of research programmes for nuclear safety.**

**The most ambitious undertaking in the field of nuclear research in Europe is certainly the newly established Sustainable Nuclear Energy Technology Platform (SNE-TP).**

## *SARNET*

*A Network of Excellence  
(6<sup>th</sup> European Commission Framework Programme)  
associating 51 European Research and Development Organisations  
Field of activities: PWR severe accidents*



France, Great Britain, Hungary, Austria, Belgium, Italy, Switzerland, Greece, Germany, Romania, Bulgaria, Slovakia, Slovenia, Lithuania, Holland, Czech Republic, Spain, Finland and Canada

**SARNET R&D activities involve approximately  
350 researchers and PhD students**

## *SARNET Objectives*

- Coordinated by IRSN in collaboration with several organisations (CEA, FZK, GRS, RIT...)

- **Main Objectives**

- Sharing knowledge and organising R&D activities regarding Severe Accidents in order to clarify unsolved questions as efficiently as possible.

- Passing down and preserving knowledge banks.

- Integrating results into experimental databases (DATANET).

- Capitalising knowledge in the ASTEC integral code - developed by IRSN and GRS - which became an European reference in terms of severe accident studies.

- Training young researchers and engineers.

- **Key Dates**

- Network launched in April 2004 (contract with the European Commission: 4.5 years)

- SARNET should renew its contract with the European Commission for 4 years (2009-2013)

## *ETSON*

**Since May 2006, another concrete step has been taken in realising the idea of EUROSAFE: the foundation of the European TSO Network (ETSON) by AVN, GRS and IRSN which is supported by the other partners in the EUROSAFE programme committee CSN, HSE, SKI and VTT.**

**The network is also open to other European TSOs. The aims of the network are:**

- to promote a European scientific-technical TSO network in the field of nuclear safety,
- to provide a forum for the exchange of R&D results and experience in the field of safety assessments,
- to harmonise nuclear safety assessment practices in Europe, and

- to establish initiatives for the definition and implementation of European research programmes.

## *Sustainable Nuclear Energy Technology Platform (SNE-TP)*

**Officially launched on the 21st September in Brussels.**

**SNE-TP aims at coordinating Research, Development, Demonstration and Deployment (RDD&D) in the field of nuclear fission energy.**

**It gathers stakeholders from industry, research organisations, Technical Safety Organisations (TSO), universities and national representatives.**

**The Vision Report is the basic document ([www.snetp.eu](http://www.snetp.eu)).**

**Governing Board and Executive Committee established 29/30th October 2007.**

## *Summary and Conclusions*

**Research has a leading role in maintaining the safety of operating reactors.**

**Research efforts are to be continued in several areas with emphasis on advanced methods that integrate latest experimental findings into the computational tools.**

**Capitalising the knowledge under convenient & ready-to-use forms is a necessity, according to the huge amount of information to be treated.**

**Maintaining and modernising experimental infrastructures is necessary to resolve specific safety issues of today and to provide the possibility to investigate safety issues that may arise.**

**Transforming international cooperation in sustainable networks will enable safety research to promote nuclear safety in the future.**

**SESSION 2**

**RESEARCH AND FACILITY NEEDS FOR NEW REACTORS (G-III, G-III+)**





# RESEARCH REQUIREMENTS EMERGING FROM LICENSING AND NEW PLANT CONSTRUCTION: LESSONS LEARNED

**Dr. Lasse Reiman**  
*Director, STUK, Finland*

## Contents

- The Finnish National Nuclear Safety Programmes
  - The Finnish National Nuclear Safety Programmes 1990 - 2010
  - SAFIR2010 funding by research area in 2007 and funding sources
- CNRA/CSNI role in the Finnish national nuclear safety research
- Lessons learned
- Future international challenges
- Conclusions

## General principles concerning safe use of nuclear energy in Finland

- Government Resolution 395/1991, 6 §
  - Nuclear power plant safety and the design of its safety systems shall be substantiated by accident analyses and probabilistic safety analyses
  - Analyses shall be maintained and revised if necessary, taking into account operating experience, the results of experimental research and advancement of calculating methods
- Government Resolution 395/1991, 27 §
  - Operating experience from nuclear power plants as well as results of safety research shall be systematically followed and assessed
  - For further safety enhancement, actions shall be taken which can be regarded as justified considering operating experience and the results of safety research as well as the advancement of science and technology

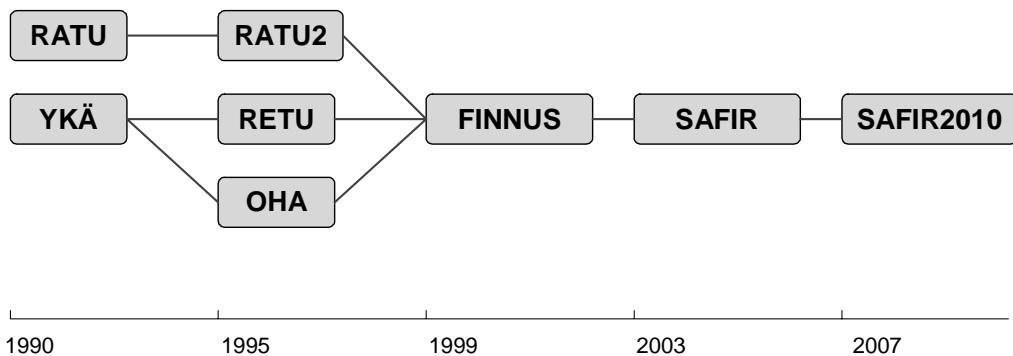
⇒ a strong commitment to SAHARA principle and continuous improvement of safety

SÄTEILYTURVAKESKUS • STRÅLSÄKERHETSCENTRALEN  
RADIATION AND NUCLEAR SAFETY AUTHORITY

LR  
December 5, 2007



## The Finnish National Nuclear Safety Programmes 1990 - 2010



funding: NPPs, the Ministry of Trade and Industry, VTT, STUK, other financiers

Nuclear Energy Act 53 §

funding: VYR, VTT, other financiers

SÄTEILYTURVAKESKUS • STRÅLSÄKERHETSCENTRALEN  
RADIATION AND NUCLEAR SAFETY AUTHORITY

LR  
December 5, 2007



## The Finnish National Nuclear Safety Programmes

### Amendment of the Nuclear Energy Act in 2003, 53§

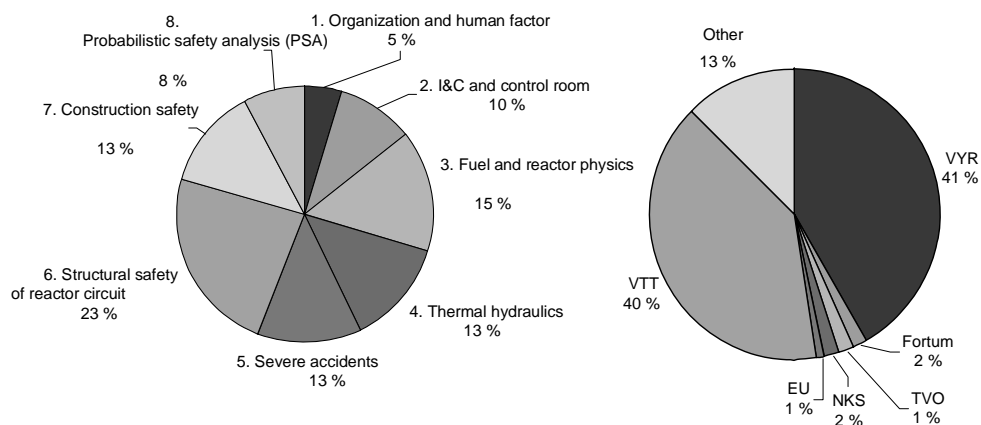
- ensures funding of the national nuclear safety research programmes (annual utility fees)
- the research shall ensure the availability of sufficient and comprehensive expertise and methods for the disposal of the authority in case of unforeseeable safety issues
- the research shall be of high scientific quality

### STUK and TSO support

- STUK orders TSO support for oversight as needed and independently from the research programmes

## SAFIR2010 funding by research area in 2007 and funding sources

Total volume in 2007 6 million € (~ 50% of the reactor safety research in Finland)



## Safety challenges of the SAFIR2010 research programme

### Plant design, construction and change management

- taking science and technology development into account
- severe accidents

### Safety assessment

- Deterministic analysis and experiments (high fuel burn-up, models)
- Risk-informed safety management (living PSA applications, internal and external threats, automation and human factors)
- Plant life cycle and comprehensive safety assessment

### Ageing management

- Loviisa 1 and 2 plant units operation license application, 50 years operation lifetime
- Olkiluoto 1 and 2 plant units operation license application, 40 years operation lifetime 2018, periodic safety review 2008
- Olkiluoto 3 design basis 60 years operation lifetime

### Safety culture, organisation and human factors

- assessment method improvement
- safety management and change management
- networking operational environment
- generation change
- new technologies

## CNRA/CSNI role in the Finnish national nuclear safety research

CSNI research programmes support the Finnish national nuclear safety research programme (SAFIR) and their results are utilized in developing national safety assessment capabilities.

CSNI research programmes are closely linked to the national research programme and its specific projects (see appendix 1).

### Current Finnish participation in the CSNI research programmes:

- Cabri Water Loop Project
- SCIP (Studsvik Cladding Integrity Project)
- Halden Reactor Project
- MCCI (Melt Coolability and Concrete Interaction)
- THAI
- BIP
- SCAP
- ROSA
- SETH 2
- USNRC/CAMP
- USNRC/CSARP
- PRISME (Fire propagation)
- COMPSIS Project
- FIRE (Fire Incident Records Exchange Project)
- ICDE (International Common-Cause Data Exchange)
- OPDE (Piping Failure Data Exchange)

## Experiences from Olkiluoto 3 project

### Factors having effects on the project progress

- Too ambitious original schedule
  - Underestimation of time needed for detailed design
- Lack of skills in managing a large construction project
  - inadequate designer resources at the beginning
  - choice of subcontractors with limited experience and competence
  - inadequate control of contractors by Areva and licensee
  - inadequate communication between Areva NP and its contractors
  - misunderstanding of the regulatory and licensing system
- Manufacturing and construction challenges
  - deterioration of the global manufacturing infrastructure
  - difficulties in qualifying new manufacturing technologies
  - quality problems in the construction and manufacturing

## Lessons learned (1)

- Current business environment and networking of the suppliers have altered the design and construction of nuclear power plants
  - nuclear safety and quality requirements in the whole chain of the suppliers
  - safety culture of all suppliers
- In the research programmes appropriate attention should be given to
  - New technology and manufacturing technologies such as bimetallic joints in the safe-ends and forging of cast of hot and gold legs challenge expertise and national research programme
    - maturity of the technology
    - inspectability issues
    - ageing issues
    - fire retardant cables

## Lessons learned (2)

- New plant features
  - passive systems
  - new equipment
  - digital I&C
  
- Safety culture and networking of the suppliers
  
- Timely and effective licensing process of new NPPs needs
  - well validated analytical and other tools
  - competent experts
  - international networking in the use of TSOs (in appendix 2 examples have been given how STUK has used TSOs in the licensing process of OL3 )

## Future international challenges

- Maintain and develop competence and methods; training of new experts in the nuclear field
  
- Preserve knowledge base; knowledge management
  
- Preserve active test facilities
  - various types of test facilities are needed
  - both large scale facilities as ROSA and small scale facilities as PACTEL
  
- Maintain competent international research networks to support national licensing efforts
  
- CNRA/CSNI role as a coordinator in international research programs

## Conclusions

- Long-term planning and stable funding of national research programmes have been crucial in maintaining and developing nuclear safety competence in Finland
- Modernization and safety improvements of operating NPPs have given opportunities to apply the expertise and methods attracting competent people
- CNRA/CSNI research programmes provide valuable support to our national programmes

## Appendix 1: CNRA/CSNI role in the Finnish national nuclear safety research programme

Topic in national research programme	Supported by OECD research programme
Accidents during shutdown	PKL experiments
Validation of APROS code	PKL and ROSA experiments
Melt-concrete interactions	MCCI2
Hydrogen distribution and combustion	SETH2 and THAI
Melt-coolant interactions	SERENA2
New fuel criteria (LOCA and RIA)	CAPRI and Halden LOCA test programme
Cladding integrity programme	SCIP experiments in Studsvik
Degradation caused by environmental effects	OECD/NEA SCAP, Halden project

## Appendix 1: CNRA/CSNI role in the Finnish national nuclear safety research programme

Topic in national research programme	Supported by OECD research programme
Typical PSA fire scenarios with extended fire analysis software for fire spreading assessment	PRISME
Design and evaluation of control rooms and man-machine interfaces	Halden project
Ageing of electrical and I&C technology	SCAP
Human reliability in PRA	Halden project
Maintaining of Knowledge in reactor physics	NEA WPNCS

## Appendix 2: Technical support to Olkiluoto 3 Review: Finnish organisations

- VTT: advice and independent analysis of several topics including postulated accidents, severe accidents, PSA, containment design, water chemistry and I&C validation; tests including simulation of aircraft crash and of cable fires
- Lappeenranta Technical University: tests and assessment of severe accident management approach
- Nemko: Electric systems, EMC
- Pontek: Construction design
- Inspecta: Piping design



## Appendix 2: Technical Support of Olkiluoto 3 Review: Examples of Design Basis Analyses

- Main steam line break (VTT)
- Main coolant pump seizure (VTT)
- ATWS (VTT, ISaR)
- SB LOCA Boron Dilution Analysis (ISaR)
- Loss of offsite power (VTT)
- Small break LOCA (VTT)
- Steam Generator Tube Rupture (VTT, ISaR)
- Steam Generator Tube Rupture at hot zero power (ISaR)
- Large break LOCA (VTT)
- Feedwater line break (VTT, ISaR)
- Containment behaviour during main steam line break (VTT)
- Containment behaviour during large break LOCA (VTT)

## Appendix 2: Technical support to Olkiluoto 3 Review: Foreign organisations

- GRS Germany: assessment of Break Preclusion concept for primary and secondary systems; independent analysis and assessment of aircraft crash protection approach
- ISaR Germany: independent analysis of specific accidents, assessment of the ECCS, hydrogen control in containment
- Belgian consultant: digital I&C issues

DGSRN and IRSN France: exchange of information on assessment of several design topics, in specific I&C systems



**EVOLUTION OF SAFETY RESEARCH DEMANDS  
FOR NEW REACTOR DESIGNS AND WAYS TO ADDRESS THEM**

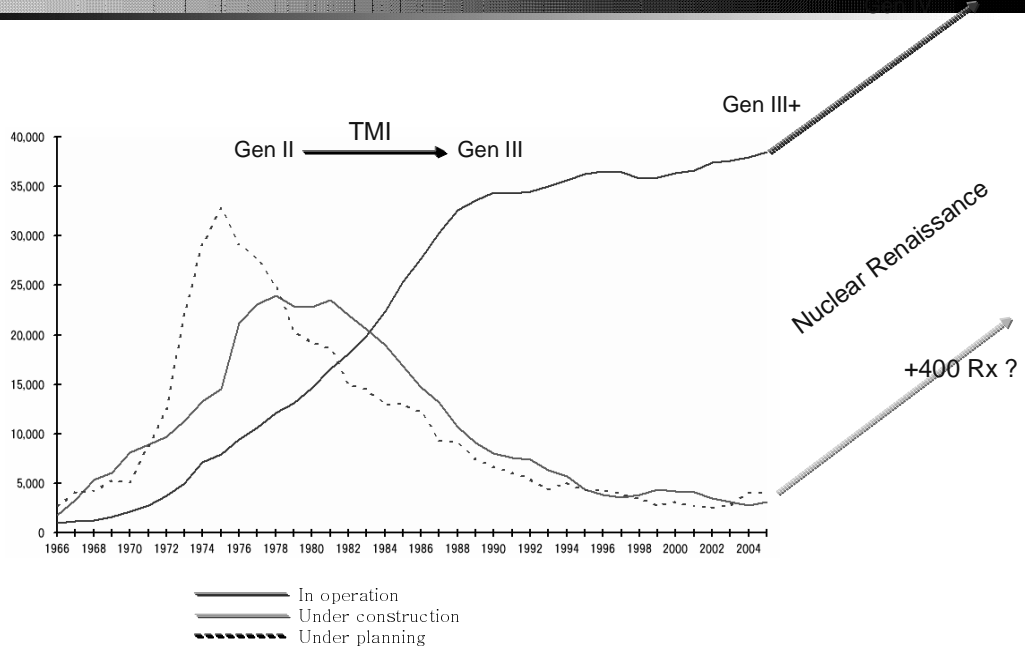
**Dr. Jaejoo Ha**  
*Vice President, KAERI, Korea*

Contents

- Trends on Nuclear Energy
- Emerging Demands
- Safety Research Framework in Korea
- Conclusions



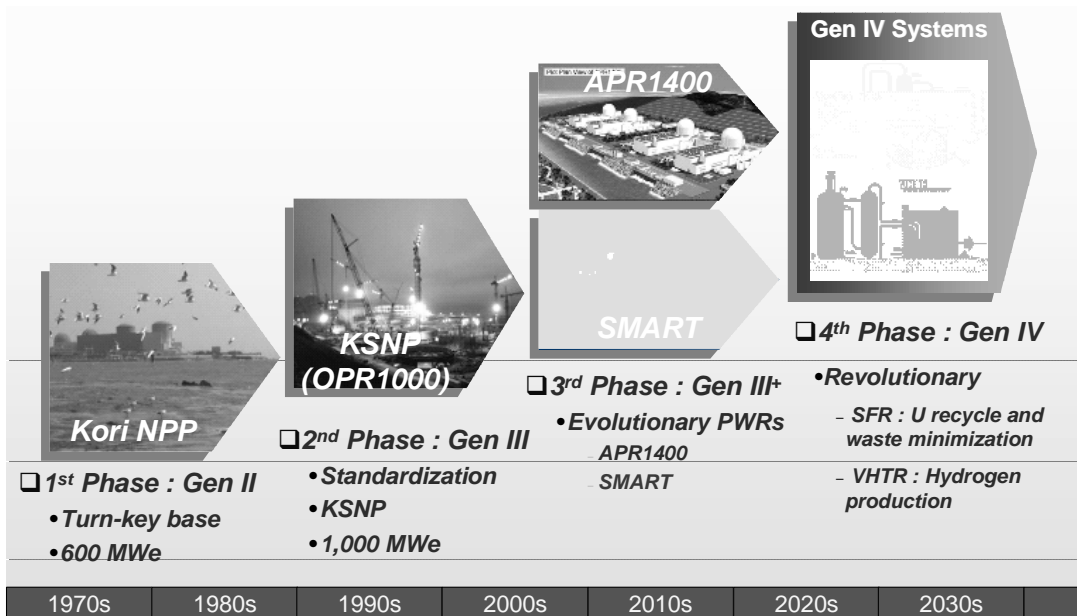
## World Trends on Nuclear Power



(Source: Nuclear Encyclopedia, ATOMICA 01-07-05-01)



## Korean Nuclear Reactor Systems: Past & Future



## We want more reactors with higher safety and better economics

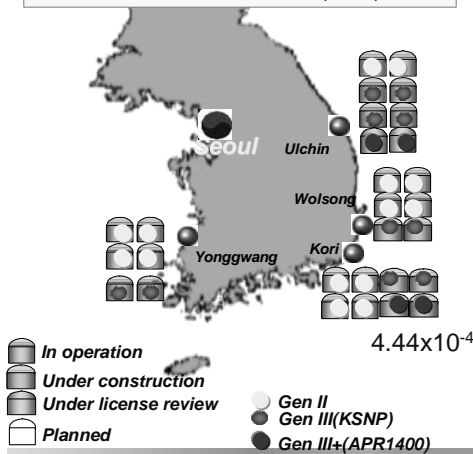
1. **More plants in a site, in a country, and in the world**
  - How to ensure no significant additional risk by new NPPs ?
2. **Longer design life : 40 → 60 → 80 yrs**
  - How to assess & license design life ?
3. **More extreme environments**
  - How to cope with stronger earthquakes, wind, tsunami, fire... ?
4. **Stronger concerns on security and physical protection**
  - How much and how to consider terrors and sabotages ?
5. **Safety for better economics**
  - How to keep superior competitiveness over other energy sources ?
6. **More advanced assessment methodology and tools**
  - What are effective ones and how to develop them efficiently ?
7. **Loss of knowledge & facility**
  - How to sustain the existing knowledge & facility and utilize them ?



## 1. How to Ensure No Significant Additional Risks

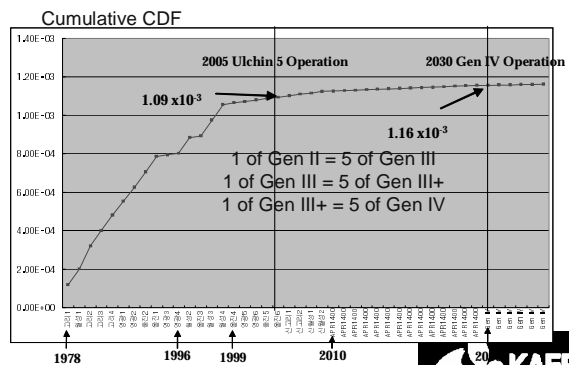
(As of Oct. 2007)

Installed Capacity (Sep. 2007)  
 Total : 67 GWe  
 Nuclear : 17.7 Gwe (26.4%)  
 Generation in 2006  
 Total : 380.9 TWh  
 Nuclear : 148.7 TWh (39%)



- In operation : 20 units
  - 16 PWRs (6 KSNPs), 4 PHWRs
- Under construction
  - 4 OPR1000s (Kori, Wolsong), 2 APR1400s (Kori)
- Under license review
  - 2 APR 1400s (Ulsin)
- Planned
  - 2 APR1400 or APR+ (Site not decided)

To build new NPPs, need saturation of total risk



## Major Contributors in Order to Ensure No Significant Additional Risks

- **Inherent Safety: Passive Safety Systems**

- More use of passive safety features for emergency core cooling, decay heat removal, containment cooling even for large power ratings
- Need for experimental infrastructure to verify the reliability and performance of passive features and to validate analytical tools
- International cooperation to maintain and utilize key facilities under way



New Test Facility, ATLAS,  
for Active & Passive Safety

- **Severe Accident Mitigation Features**

- More use of severe accident mitigation systems for in-vessel retention of molten corium or preservation of containment integrity
- Difficult to verify the performance of the mitigation features → Cooperative research in both experimental and analytical fields necessary
- Several OECD cooperative activities underway



## 2. Longer Design Life : 80 years?

- **Expanding Database of Materials Performance**

- Fundamental understanding, prediction & remedies for Proactive Technology against Material Aging Degradation
- Long-term verification of new materials (Alloy 690, etc.)
- Root cause of dissimilar weld joint cracking
- Advanced non-destructive examination methodology

- **Materials Application for Design Improvement**

- High strength & toughness RPV steels for capacity increase
- Steam generator optimization (Anti-FIV design & materials)
- Extensive application of LBB (leak-before-break) design
- Lessons learned from current materials application



International cooperative programs are underway to accumulate the common knowledge for all mankind :  
IAEA, OECD/NEA, EU-FP, USNRC, EPRI, Gen4-IF



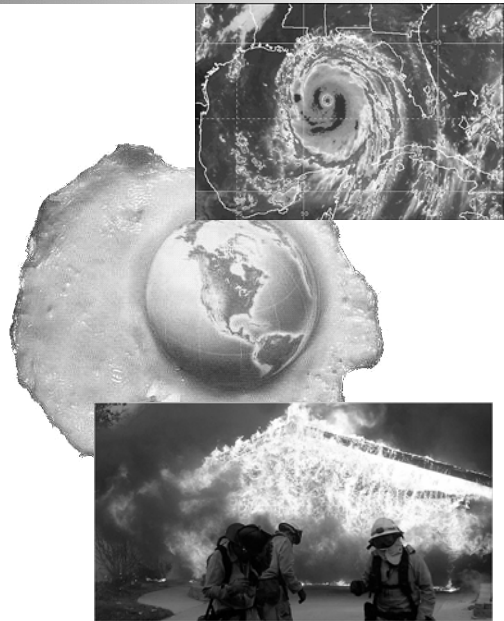
### 3. More Extreme Environments

- **Changing Environments**

- Hurricane Katrina, Typhoon
- Fires in California
- Earthquake Niikata
- Coastal erosion
- Extreme winds and tornadoes
- Tsunami
- High Summer temperature
- Extreme flooding and drought

- **Things to consider**

- How the environment change in 2100, the end of design life?
- How to consider such environments to the design ?
- How much to reflect to regulation ?



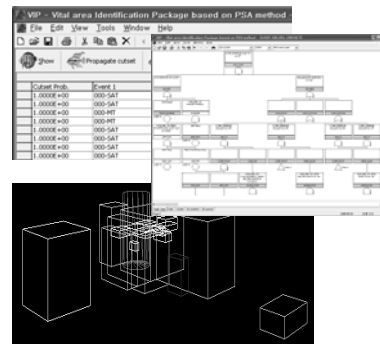
### 4. Stronger Security and Physical Protection

- **Sep. 11, 2001**

- How can we secure our new plants from the threats?

- **Things to consider**

- Aircraft crash proof containment
- Sabotage
- Reasonable and robust method
  - (ex) Integration of Safety & Security Analysis : PSA Based Vital Area Identification (VIP)



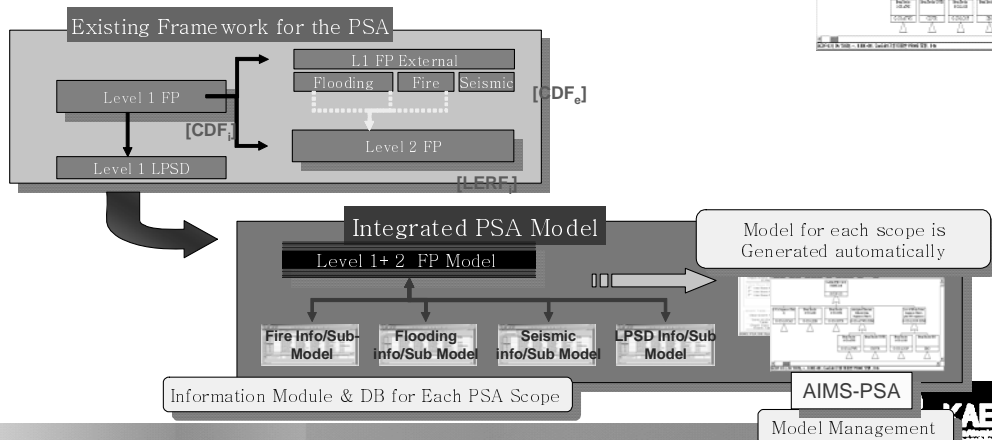
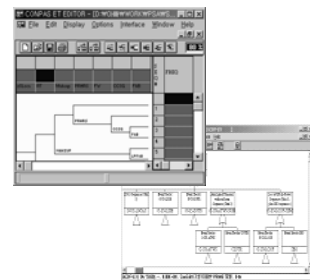
## 5. Safety Research for Better Economics

- **Larger Capacity for Economics upto 2000MW?**
  - Develop new fuels
  - Integrity and performance of high burn-up fuels
  - Manufacturability of large components
- **Longer cycle and Intelligent Operation**
  - Integrated/Objective Decision Making Process
  - Effective test, maintenance & repair
  - Intelligent monitoring & inspection
  - Digital I&C
- **Optimization of Safety and Economics**
  - Balanced Defense In Depth
  - Risk-informed/Performance-Based Design/Operation
  - Realistic safety margin evaluation via enhanced knowledge



## 6. Frameworks, Methodologies, Tools

- **Risk-informed Performance based Approach**
  - Safety Goal & Performance Goal
  - Risk-informed Design
    - Reliability Assurance Program
    - Re-definition of LLOCA in risk aspects
    - RISC (Risk-informed SSC Classification)
  - How to reduce the uncertainty & complexity ?





## • **Advanced Analysis Tools**

- Multidimensional Thermal-Hydraulic Phenomena in Advanced Systems
  - Multi-D system analysis codes: TRACE, CATHARE, MARS, . . .
  - Application of CFD codes to reactor safety problems: FLUENT, CFX, . . .
  - Need for new experimental data for validation
  - International activities by CSNI, EU, USNRC, etc.
- Realistic Evaluation with Coupled Code Calculations
  - 3-D Neutronics Code + 3-D System Thermal-hydraulic Code + Containment Code  
→ Realistic Safety Analysis
  - Thermal Hydraulic code + Structural Analysis Code → Reliable fluid-structure Interaction (e.g. flow induced vibration) analysis
  - International benchmarks for coupled safety analysis
- Uncertainty Quantification Methodology for Realistic Safety Analysis
  - Early adoption of statistical methods for DNB analysis
  - Recent adoption of realistic evaluation methodologies for LOCA analysis → BEMUSE program by CSNI

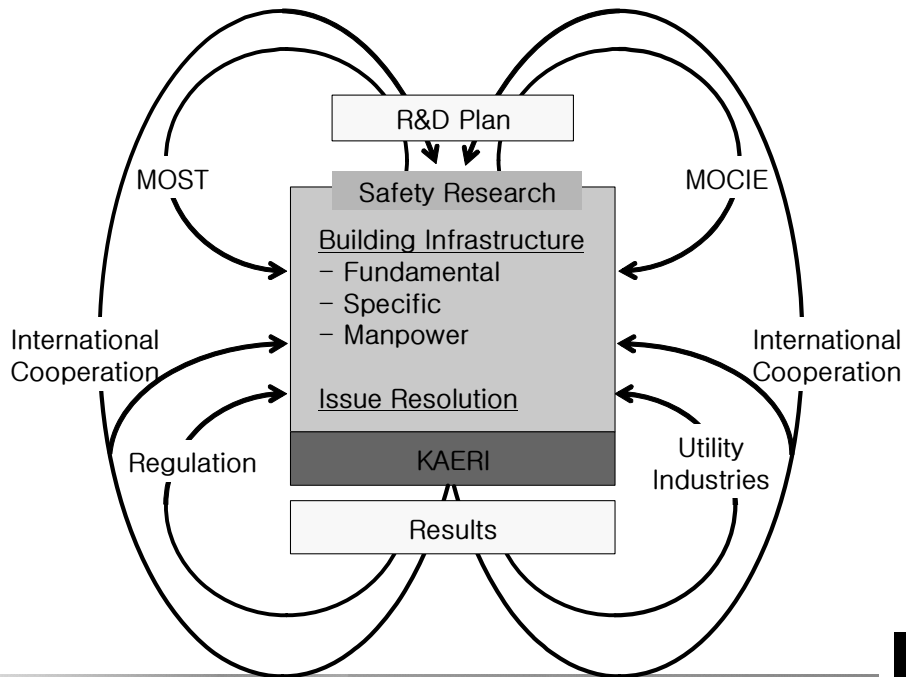


## 7. Sustain Knowledge and Facility

- **Issues**
  - Loss of experts
  - Low quality of new man power
  - Shutdown of experimental facilities
- **How can we cope with this situation?**
  - OECD's effort
  - Knowledge management in IAEA
  - IYNC, WNU,...
  - Others?

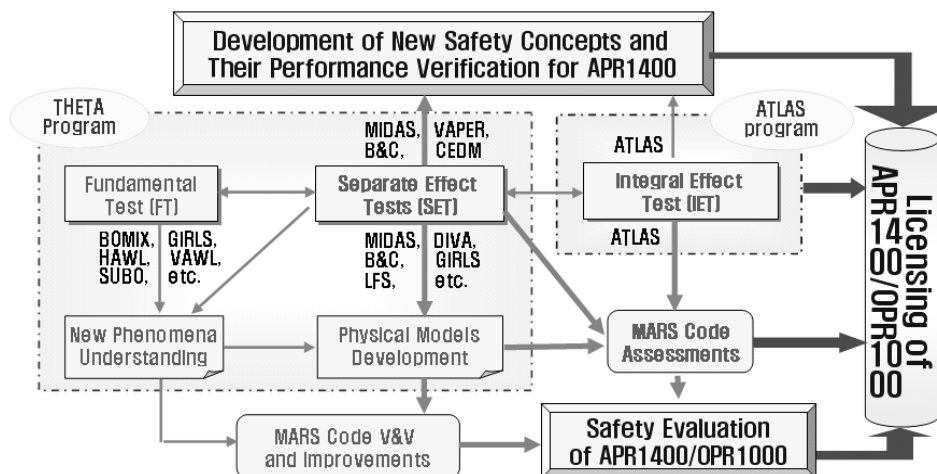


## Safety Research Framework in Korea



## Korean Experiences: APR1400 Develop./Licensing

- The technologies developed by KAERI are being transferred to domestic nuclear organizations (KINS, KHNP, etc.) under the permission by the funded organizations (MOST, MOCIE, etc.).



## Conclusions

- OECD approaches look right.
  - SERENA, COMPSIS, ISP,...
  - But, the process is slow and complicated. How to improve it?
- There are many research results
  - How can we validate the research results?
  - How to be utilized in regulation effectively?
- There are many topics.
  - What is the real common issues for Gen-III/III+?
  - How to prioritize them?
    - What is the criteria for the prioritization?
- There are many other cooperative researches
  - How to communicate ?
  - How can we handle the intellectual property?





# A UTILITY VIEWPOINT ON R&D NEEDS TO SUPPORT DESIGN, CONSTRUCTION AND OPERATION OF GENERATION III REACTORS

**Mr. Jean-Pierre Hutin**

*Vice President, Power Generation Sector, EDF, France*

## Introduction

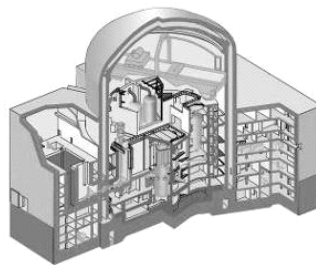
Nuclear will effectively contribute to the world energy challenge

R&D support is needed for all systems

GEN 2 : solving issues arising from operating experience

GEN 4 : concepts, design and safety demonstrations

**...and GEN 3 ?**



## Harmonizing safety demonstration methodologies and requirements

Benefits from building a fleet of "standardized" units

Different companies could agree on purchasing / operating identical units

Difficult if licensing rules and methodologies are different

Develop harmonized state-of-the-art practices, taking advantage of new simulation capacities

Corresponding R&D programs : an opportunity to close issues which have been sufficiently investigated, with international consensus

3

december 2007

EDF R&D



## Use of probabilistic approaches

Deterministic design but...

Optimization of operation and maintenance can be obtained using probabilistic approaches

More realistic assessment of risk and better understanding of uncertainties → more appropriate decisions

R&D : development of models, methodologies, applications, data collection

Will contribute to disseminate culture and knowledge related to risk and safety

Harmonization of methodologies will facilitate their use

4

december 2007

EDF R&D



## Improving man-system interface to facilitate plant operation

Provide appropriate support to the operators to facilitate their work

Take advantage of new possibilities offered by numerical simulation and high performance computers

Direct visualisation of phenomena → improving the understanding of any situation

Possibility to test decisions prior to actions ("real time simulator")

Improving human performance → benefits for safety AND cost-effectiveness !



## Supporting maintenance tasks with new technologies

Facilitate maintenance tasks to reduce risk of human error

Virtual reality for training and task preparation

RFID technology to reduce the risk of error

Wireless technology :

- to get the right information at the right moment on the spot
- to report more rapidly, making safer the link with following tasks
- improve communication between individuals, thus reducing the risk of misunderstanding

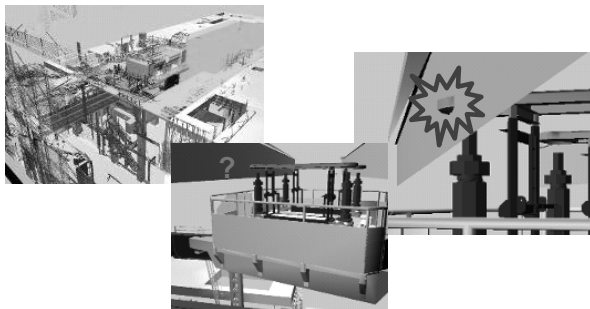
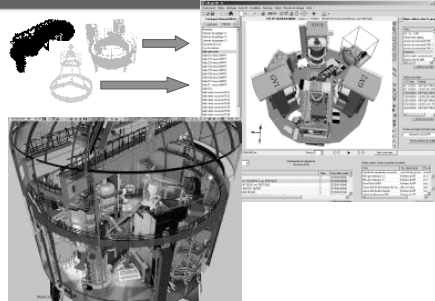
Virtual reality to optimize large components handling and storage in containment

Could include information related to radioprotection to help in reducing personal dose (the "real time radioprotection control room" ?)



## Numerical simulation for maintenance preparation and management

Optimize scenarios for large equipment handling and storage in reactor building before outage, adapt schedule in real time → *reduced outage duration and improved security*



Coupling CAD data with as-built 3-D imaging (from laser mapping system) to simulate and prepare large overhaul

7

december 2007

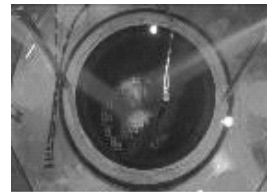
EDF R&D



## Fuel, fuel management and fuel cycle

### New fuel

- Eradicate problems associated with unresolved issues
- Higher burn-up
- More flexible operation



### New fuel management

- More flexibility for cycle duration → new safety demonstration methodologies taking advantage of increased capacity of high performance computing (full-size multi-scale and multi-physics core calculation)

### Fuel Cycle

- Closing the cycle... taking in account proliferation, minor actinides recycling, etc.

8

december 2007

EDF R&D



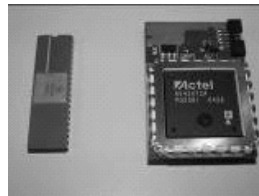


## Digital technology for Instrumentation and Control

### Licensing issues

- "off-the-shelf" technologies and components
- safety demonstration and qualification methodologies for software
- periodic testing of digital equipments

### Development of obsolescence-resistant technologies



Clone de MC6800

9

december 2007

EDF R&D



## Effective life time management

Ageing issues are unavoidable and never taken in account early enough

Always some ageing issues not completely accounted for in design : how to help future operator ?

- Lack of knowledge, data, model
- Complete investigation of all possible (?) types of degradation in order to provide plant owner / operator with what is needed to properly adress any ageing mechanisms (mitigation, surveillance, maintenance, repair, ...)

Provide elements for timely collection of relevant data

10

december 2007

EDF R&D



## Interaction between Environment and Operation

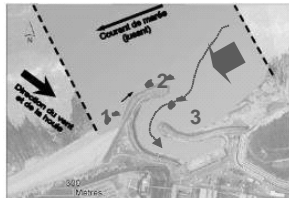
Reducing release and waste

Reducing source term

Get prepared to problems with water availability

Get prepared to more external hazards (hurricane, flood, etc)...

...Because, in the timeframe of GEN3 plant operation, climate change will make the situation worse and worse !



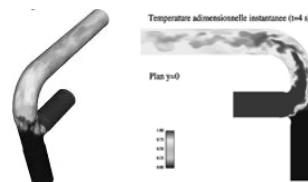
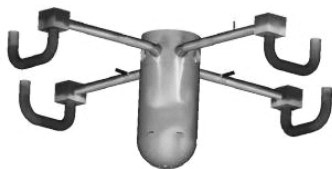
11 december 2007 EDF R&D



## Numerical simulation everywhere !

Less testing, more numerical simulation

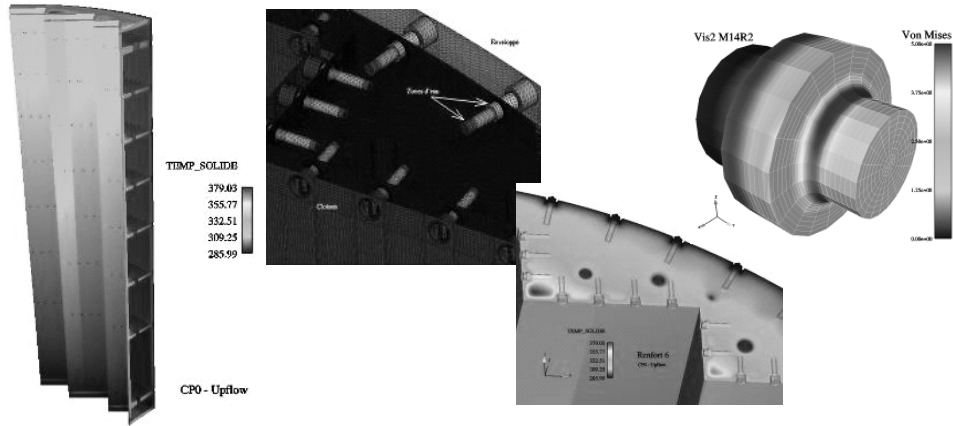
- high performance computing capacities
- Full-size multi-physics and multi-scale modelling
- ... in order to save time and money
- ... and reduce the uncertainties
- But who will keep the last testing infrastructure ?!



12 december 2007 EDF R&D



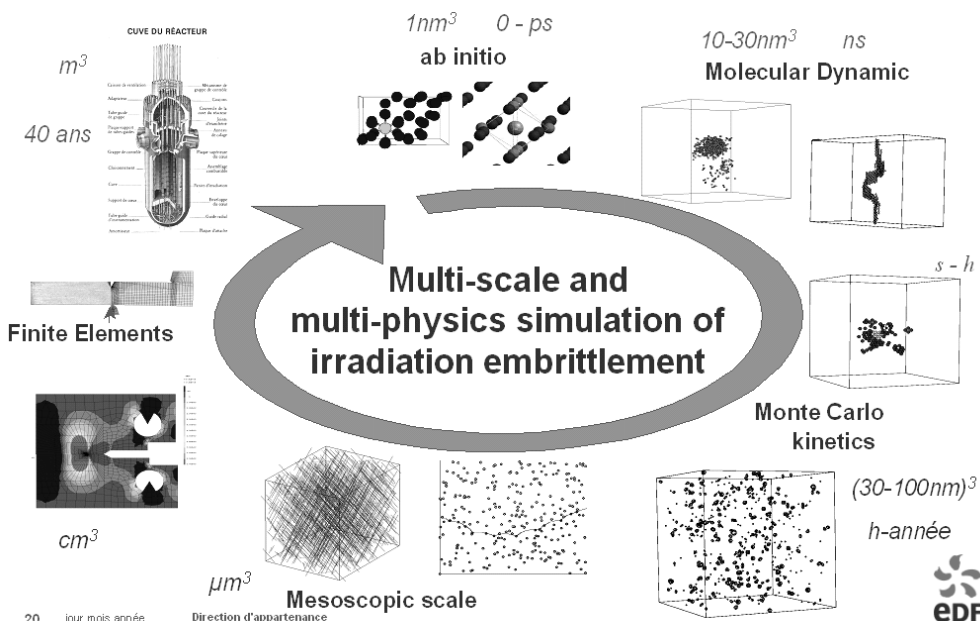
## Risk of irradiation assisted cracking of the internals baffle bolts



Complete and detailed modeling of the internals with simulation in materials, neutronic, thermohydraulic, mechanics (Code\_Aster : free on the Web !) → precise evaluation of the stress field in any bolt = estimate of the risk of cracking



## European PERFECT Project (EDF leader)



## Simulation of radiography with the Moderato code

Software simulating radiography

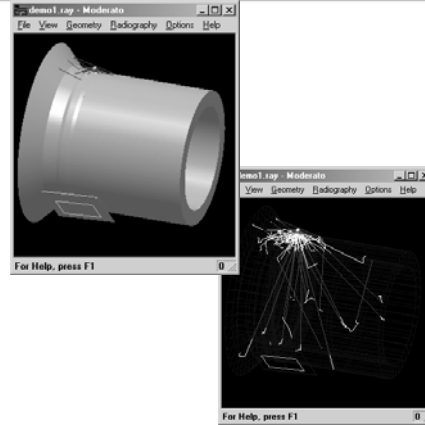
Used for performance demonstration and regulatory qualification

State of the art for simulation of radiation / matter interaction

Validation for each physical laws and through global tests

Better accuracy than with mock-ups

Important cooperation with the BAM - Berlin



*For the inspection of thick, complex parts, the simulation used to require several weeks of calculation. Using high performance computing resources (cluster of PCs in the LINUX environment) and the modification required to MODERATO, the simulation of non-destructive testing has reached unprecedented performance (four days to simulate an x-ray inspection of welds of the spray nozzles of the pressurizer)*



## After "what ?" ... how ???

More mutualisation, beyond the traditional borders

- Save money
- International consensus increases credibility for the public

OECD should play a major role to promote and support such cooperation !



*Thank you for your attention !*



## USNRC PERSPECTIVE ON RESEARCH FOR NEAR TERM REACTORS

**Mr. Bill Borchardt**

*Director, Office of New Reactors, USNRC, United States*

### U.S. NRC's Perspective on Research for Near Term Reactors



- Outline
  - Introduction
  - Background
  - Research Needs for Near Term Reactors

## U.S. NRC's Perspective on Research for Near Term Reactors



- Background

- Resurgence of Nuclear Power in the US
  - 32 new plants at 21 sites proposed by the industry
- Five different plant designs proposed
  - AP1000
  - Economic Simplified Boiling Water Reactor
  - US EPR
  - Advanced Boiling Water Reactor
  - US Advanced Pressurized Water Reactor

## U.S. NRC's Perspective on Research for Near Term Reactors



- Background

- Applicants are principally responsible for conducting tests and analysis to validate their safety case.
- U.S. NRC performs reviews and, if necessary, conducts independent confirmatory tests and analysis.
- Research has provided the foundation for our ongoing reviews
  - Provided confirmatory data of safety systems that support NRC ability to review current designs
    - Thermal Hydraulic tests of AP600, AP1000, SBWR, ESBWR
  - Provided data to support updates to analytical tools
    - TRACE
    - MELCOR

## U.S. NRC's Perspective on Research for Near Term Reactors



- Research will continue to be needed to confirm new or unique features for near term reactor designs.
- Other research needs likely to be similar to that for operating reactors.
  - Address emerging safety issues
  - Address new technologies

## U.S. NRC's Perspective on Research for Near Term Reactors



- Knowledge Management
  - Research Knowledge must be transferred into the regulatory structure to support near term reviews.  
Examples:
    - Improved understanding of seismic hazards need to be translated into new regulatory standards to support siting decisions.
    - Tornado and Hurricane wind speeds
    - Mitigating strategies for beyond design basis events

## U.S. NRC's Perspective on Research for Near Term Reactors



- Conclusion

- Research needs for near term reactors are at a transition point from developing data supporting design to supporting operational oversight.
- The research needs for these designs will focus on the confirmatory analysis the U.S. NRC needs to verify the applicants safety case.



**SESSION 3**

**R&D AND FACILITY INFRASTRUCTURE FOR ADVANCED (G-IV) REACTORS**



## SAFETY ISSUES AND RELATED R&D FOR GEN-IV CONCEPTS

**M. Jean-Louis Carbonnier**  
*CEA, France*

### Gen IV Safety Goals



- **Three specific safety goals “to be used to stimulate the search for innovative nuclear energy systems and to motivate and guide the R&D on Generation IV systems”:**
  - Generation IV nuclear energy systems operations will excel in safety and reliability.
  - Generation IV nuclear energy systems will have a very low likelihood and degree of reactor core damage.
  - Generation IV nuclear energy systems will eliminate the need for offsite emergency response.
- **The RSWG has focused on defining the attributes and identifying methodological advances that might be necessary to achieve or demonstrate achievement of these goals.**
- **The improved waste management which is also a Gen IV goal is a contribution to the safety of nuclear systems.**

## Safety approach for future reactors: Foundation



- The safety approach is based mainly on the Defence-in-Depth (DiD), taking into account the experience feedback and the limited knowledge of phenomena occurring in accident conditions.
- DiD has to combine deterministic considerations complemented by insights from probabilistic studies.
- The safety objectives applicable to the Gen III plants are already very ambitious, aiming at a very high level of protection to the operators, the environment and the public. They are used as the basis for the safety approach for future reactors.
- A “robust” safety demonstration is sought for, based on high confidence on the identification of risks, initiating events and sequences, the capability to assess them and to assess the uncertainties, and the capability to master them.

## Future SFR: Consideration of Severe Accidents



- **With regard to safety, Sodium-Cooled Fast Reactors are characterized by strong advantages but also by some drawbacks :**
  - The core is not in the most severe reactivity configuration.
  - The core might have a positive voiding reactivity effect.
  - Sodium is chemically reactive (air, water...) .
- **Consideration of severe accidents is a key point during the design phase for defining the safety architecture .**
- **In particular, accident situations which are “dealt with”, or “practically eliminated”, have to be identified for :**
  - Preventing and mitigating the “dealt with” situations.
  - Justifying and demonstrating the “practical elimination” of some particular situations (ie : large mechanical energy release). The demonstration is developed on a case-by-case basis combining deterministic and probabilistic assessments, and engineering judgement.

## Typical GEN IV SFR safety Objectives



- Resistance to core compaction (earthquake, etc.)
- Favorable reactivity balance (particularly the Na void worth)
- Limitation of core initial excess reactivity (Internal Breeding Gain # 0)
- Emulation of passive mechanisms in accident situations
  - Neutron leakage (plenum)
  - Natural convection in primary circuit
  - Passive decay heat removal by design
- Prevent or practically exclude high-energy accident sequences in the event of a core meltdown and other events with unacceptable consequences (loss of all DHRs, core support failure)
- Limit the risk due to sodium chemistry (sodium-water or sodium-air reactions)
- Make the safety demonstration robustness increased
- Consider fuel options giving more margins

## Trends for a high-performance safety-enhanced core

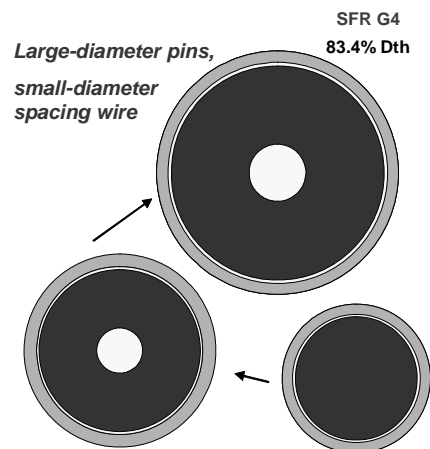


Enhanced safety by reduction of the risk of core meltdown :

- particular attention to reduced void worth
- minimization of initial core reactivity excess

Attractive solutions exist for reduced void worth, also compatible with a low reactivity loss :

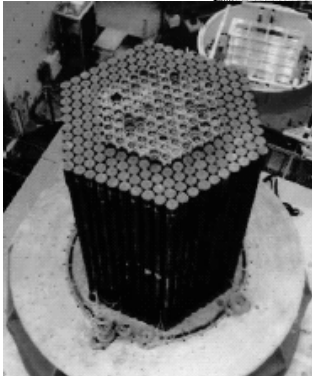
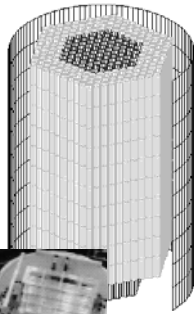
- Fuel fraction  $\nearrow$  and sodium fraction  $\searrow$  in the core
- Core volume  $\searrow$ , core H/D  $\searrow$  (neutron leakage)
- Dense fuel (carbide fuel)
- Sodium upper plenum
- ...



## Precluding core compaction effects



3D calculations  
SYMPHONY  
Mock up



### Elimination of compaction mechanisms

- Negative reactivity trips in PHX: feedback
- seismic analysis improvement

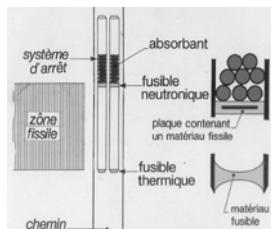
### Intrinsic limitation of core sensitivity to compaction effects

- Improved pads design (stiffness) and implementation (2 levels of pads)
- Rigid ringing at accident dedicated pads level

### Search for monitoring core geometry/compactness

- Ultra Sonic measurement of diameter
- Frequency content Analysis of neutron flux (fission chambers)

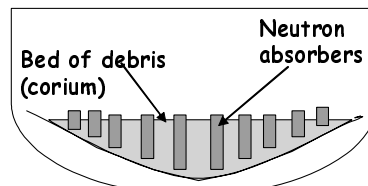
## Resistance to severe accidents



**Passive systems to avoid severe accidents**

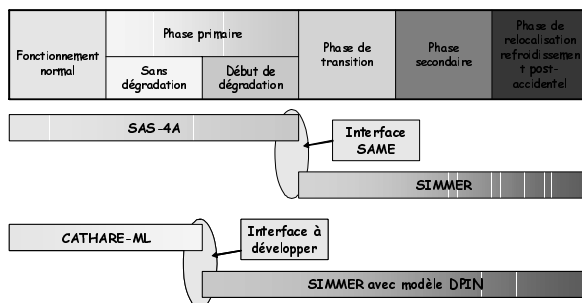
- Provisions for mitigating the core melting risk and, in the event of a core meltdown, for preventing high-energy accident sequences

- Provisions for core meltdown safety management (core catcher, decay heat removal)



**Core catcher with neutron absorbers**

### Complex modeling (codes)



## Gas-cooled Fast Reactor (GFR) : Safety Issues



- **Main safety challenges:**

- High power density (range of 50 - 100 MWth/m<sup>3</sup>) and low thermal inertia : need for reliable decay heat removal systems
- High transient temperatures are managed with a refractory fuel
- prevention and management of severe plant conditions through specific and innovative approaches

- An ad-hoc safety approach is required that relies on intrinsic core/fuel properties supplemented with additional safety provisions – active and/or passive - as needed.

- The development of an innovative fuel is the foundation of the GFR safety characteristics

## Safety Orientations of the GFR



- **The GFR is based on a cold and refractory fuel element**

- UPuC + SiC-clad
- Operating Temperature around 1200°C with severe degradation > 2000°C

- **The fast neutrons core presents assets**

- No significant void effect, moderated effect due to water/air ingress

- **Loss of coolant accidents require specific safety systems**

- Gas must circulate in all circumstances
  - Very weak short term pumping power
  - Long term natural circulation
- Enough Pressure must be kept

- **Severe accidents**

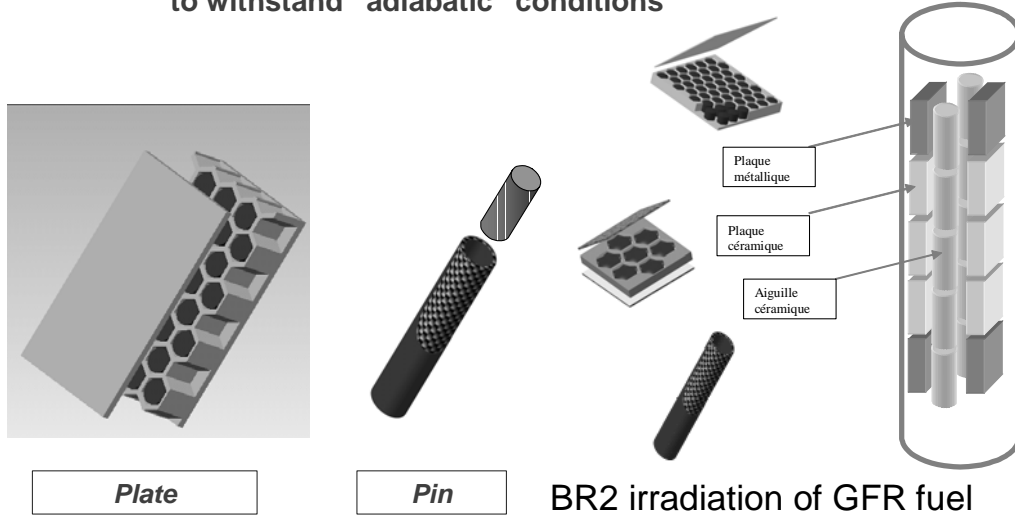
- On-going characterisation of core materials from 2000°C to 3000°C

## GFR : Fuel robustness



high temperatures, nominal and accidental situations

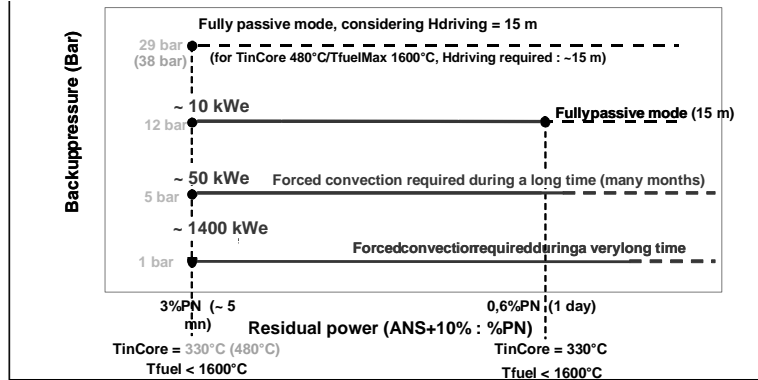
↪ Use of ceramics with good thermal conductivity, able to withstand “adiabatic” conditions



## DHR issue, selection of a strategy



Based on gas circulation, 3 possible strategies: depending on the primary pressure (backup pressure if depressurization) :



Selected option

- 1 **High Pressure strategy (DHR under fully NC)** : 30 bar required: concrete guard containment pressurized all the time => too heavy and costly solution
- 2 **Medium Pressure (DHR under mixed FC & NC)** : 5-10 bar, metallic guard cont., not pressurized in NCs => moderate pumping power: “light” self governing systems
- 3 **Low Press. (DHR under FC only)** : no guard cont. => high pumping power required



## Main design options, reactor integration principle



### Guard containment & overall systems arrangement

#### Guard containment

spherical metallic structure, enclosing the primary systems

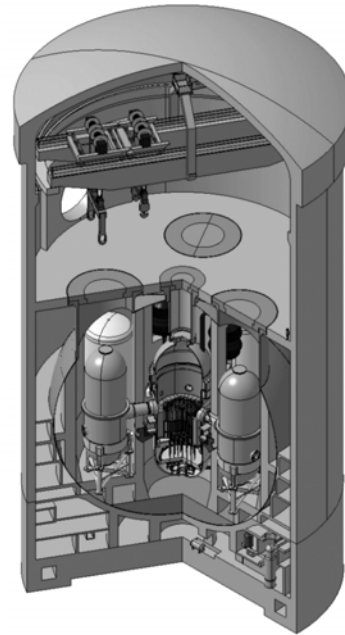
Initially : N<sub>2</sub>, 1 bar

Targeted back-up pressure : 5 -10 bar

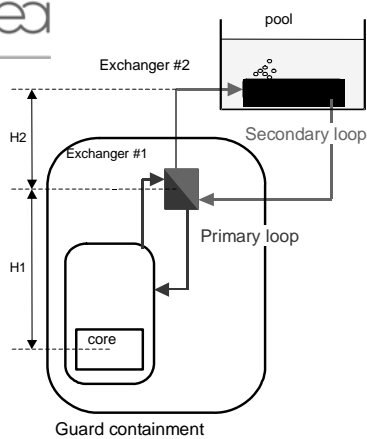
#### Reactor building,

A reinforce concrete containment protection against external hazards includes heavy handlings means

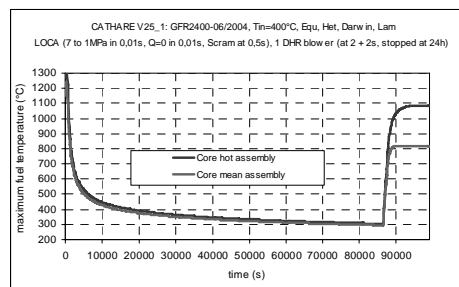
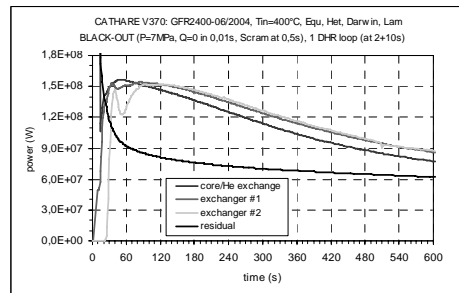
ultimate barrier



## Cathare calculations of DHR system



After 24 hours DHR removal is guaranteed by natural convection



## GFR Severe accidents program



- **Implementation of refractory materials**
  - Measure margins before core degradation
  - Identify potential cliff edge effects
    - → new phenomenology for severe accidents (different from melting)
- **Deterministic scenarios**
  - Identify mechanisms of elementary degradation
  - Model the types of possible degradation
- **Mitigation systems**
  - Evaluate emergency cooling devices
  - Propose re-criticality mitigation
- **Calculation Tools and input data**
  - Cathare + Simmer/Astec adaptation & qualification
  - Structural materials properties, Design geometry
  - Reactivity feedbacks

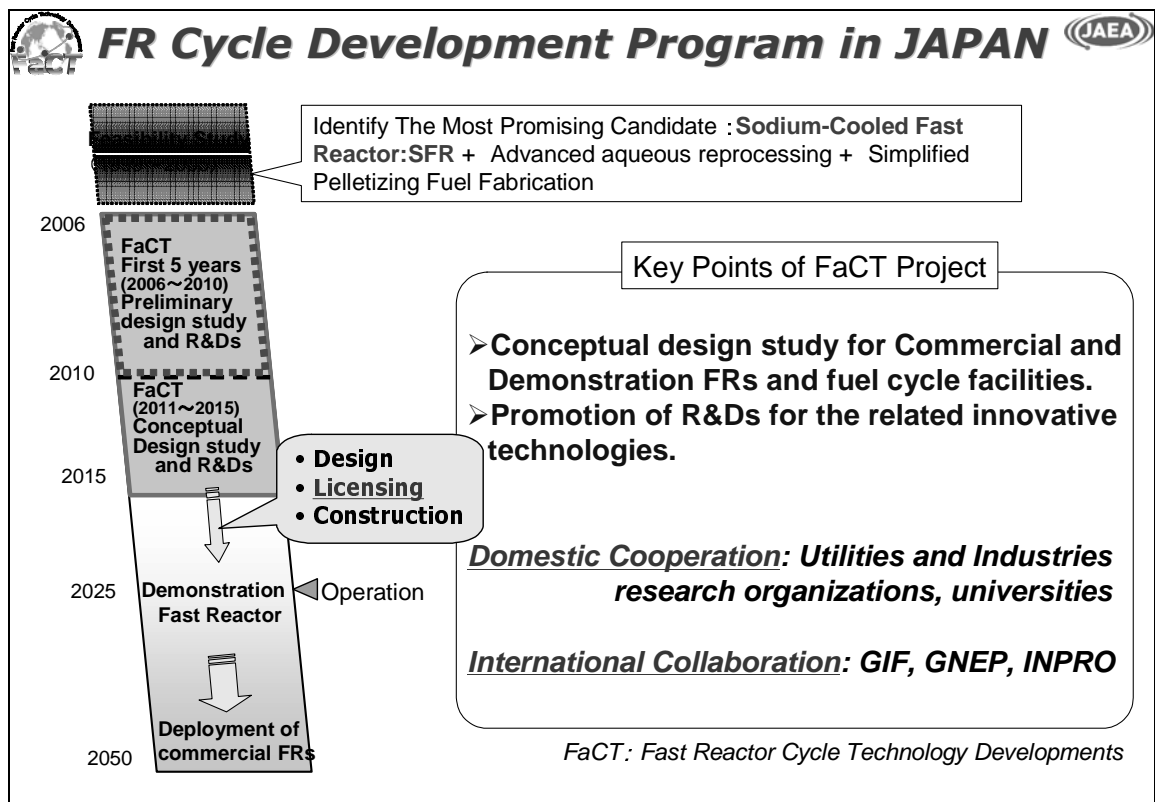
## Safety related issues for VHTR



- *Confinement: optimum share between different barriers (coated particle, primary system, confinement/containment)*
- *Severe accident approach*
- *Credit for passive safety features*
- *Stochastic behavior of Pebble Bed Reactors*
- *Combined safety assessment of VHTRs and co-located facilities (H2 production...)*
- *Materials codes and standards*
- *Radiological source term*

# SAFETY DESIGN CONCEPT OF ADVANCED SODIUM FAST REACTOR

Mr. Shoji Kotake<sup>1</sup>  
 JAEA, Japan



1. Representing Mr. Yutaka Sagayama.



## Development Targets in the FaCT Project



Development target index		Development targets
Safety and Reliability		SR-1 Ensuring a safety level equivalent to future LWRs and related cycle facilities SR-2 Ensuring a reliability level equivalent to future LWRs and related cycle facilities
Sustain-ability	Environmental Protection	EP-1 Radiation effect under normal conditions EP-2 Suppression of material emissions to the environment
	Waste Management	WM-1 Reduction of waste amount generated WM-2 Improvement in waste quality WM-3 Reduction of radio-toxicity of radioactive waste
	Efficient Utilization of Nuclear Fuel Resources	UR-1 Breeding ratio
Economic Competitiveness		EC-1 Power generating cost EC-2 Investment risk EC-3 External cost
Nuclear Non-Proliferation		NP-1 Non-proliferation NP-2 System design and technology development of physical protection



## Design Requirements in FaCT



### **-Safety and Reliability-**

*SR-1.1 Significant risk of radiation exposure to the public in the vicinity shall be eliminated within design basis events through safety measures based on the defense-in-depth principle.*

*SR-1.2 The reactor system shall be designed to prevent the occurrence of a situation that initiates an offsite emergency response.*

*SR-1.3 Total core damage frequency (CDF) shall be less than  $10^{-6}$ /reactor-year considering multiple units in a site, and total frequency of loss of containment function in core damage conditions (CFF) shall be less than  $10^{-7}$ /reactor-year.*

*SR-2.1 Adequate maintenance/repair rule shall be developed and design concept shall be well fitted with this rule. Inspection devices shall be suitably developed.*

Consistent with the safety-related goals or user requirements in GIF and IAEA/INPRO



## **General Safety Characteristics of SFR**



### Neutronics: *common to FR Core*

- Negative reactivity feed back eases any power transients of DBEs with the help of Doppler effect.
- Not in the most reactive configuration of the reactor core, Hypothetical core voiding or fuel compaction might lead to positive reactivity insertion.

### Coolant: *specific to Sodium system*

- High thermal conductivity and high boiling temperature allow to make the liquid phase heat transport system with low pressure. LOCA will be prevented by the back up structures without coolant injection.
- Chemical reaction with air or water may cause damage on the safety functions.



## **Lessons from the Experiences(1)**



### General

- The former programs such as CRBRP, PFR, SNR-300, SPX, MONJU demonstrated that the sodium-cooled FR technologies is feasible and licensable.
- Design basis accidents are rather benign in LMRs, with a low pressure system and single-phase coolant system; i.e., no LOCA
- CDA (Core Disruptive Accident) was a crucial safety issue in the licensing procedure of CRBRP, PFR, SNR-300, SPX, MONJU and so on.



## **Lessons from the Experiences(2)**



### CDA issue

#### **Containment approach (up to 1980s)**

- Containment function against the mechanical energy release due to severe criticality events has been evaluated, where robust design of the RV and CV were required.
- R & D efforts have been in direction to reduce the released energy.
- From a simplified theoretical approach of the Bethe-Tait accident to the Mechanistic approach, where the comprehensive efforts for computer code development and experimental data acquisition of CDA phenomenology have been achieved.

#### **Passive safety approach (1990s)**

- PRISM tried to eliminate the CDA issue in the licensing procedure by featuring passive safety, which would prevent core damage under severe plant conditions.
- Nevertheless the safety evaluation against mechanical energy release was required in the pre-application safety evaluation conducted by NRC.



## **Safety Design Requirements in future SFR**



### The approach against CDA shall be altered.

- From **evaluation of the released energy to eliminate the opportunity for exceeding the re-criticality by adopting design measure; i.e., Recriticality-free core concept.**
- In order to eliminate the mechanical energy release during CDA, design extension conditions of the severe plant conditions are taken account into the design at the beginning of the conceptual design.
  - Passive prevention measures, both shutdown and cooling
  - Recriticality-free core with ensuring the stable cooling for In-Vessel Retention
- Function of the design measures shall be realized by considering simplicity of its mechanism, testability, well-simulated experiments for the demonstration.



## ***Proposals to Regulatory Side (1)***

- ◆ The future licensing procedure of SFRs shall reflect the past experiences.
  - Several SFR's licensing practices has already been made in some countries (CRBRP, PFR, SPX, SNR-300, Monju and so on)
- ◆ Passive safety features shall be addressed as a significant safety functions for future nuclear system. Its reliability, testability and well simulated experiments shall be clarified.
- ◆ Provided that there is no challenge to the containment vessel under CDA conditions by adopting the recriticality-free concept, rational regulatory treatment of CDA in future SFRs is required. It is expected that the CDA issue will be no longer regulatory matter in the commercial era of SFRs.



## ***Proposals to Regulatory Side (2)***

- ◆ R&D for regulatory data base to check the applicant's evaluation will be required as preparation for future licensing.
  - Experimental investigation of fuel failure behaviors (including MA fuel), post accident material relocation and cooling
  - Development of guideline for application of PSA to advanced reactors; procedure, preparation of data, treatment of uncertainty, including data base of SFR operational experience
  - Experimental evaluation of passive safety features and development of evaluation tool





**SAFETY DESIGN AND R&D ISSUES  
FOR ADVANCED SODIUM-COOLED FAST REACTORS**

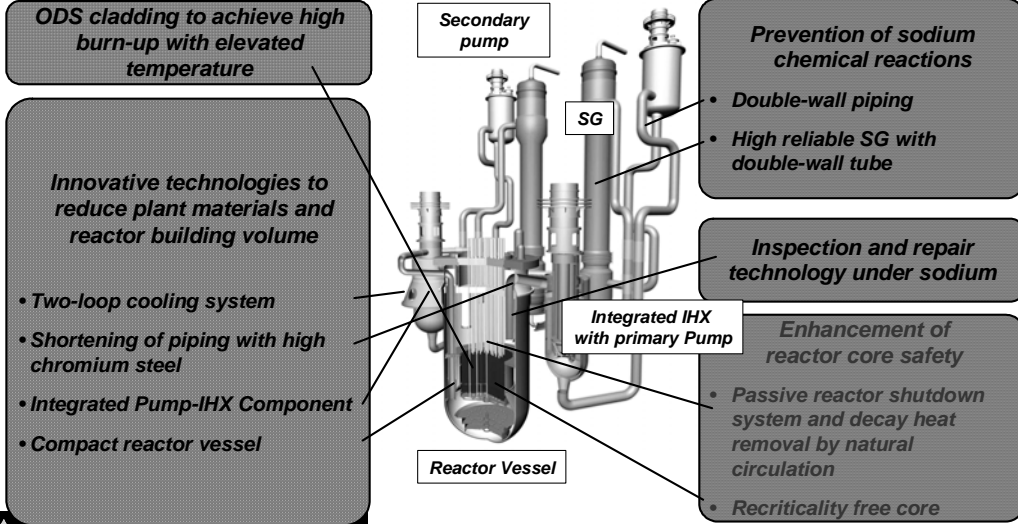
**Mr. Yoshio Shimakawa**  
*MFR, Japan*

## ***Contents***

- ◆ ***Innovative Technologies Applied to the JSFR Design***
- ◆ ***Framework of Safety Assurance***
- ◆ ***Safety Design of JSFR***
  - ***Reactor Shutdown Function***
  - ***Core Cooling Function***
  - ***Containment Function***

## Innovative Technologies Applied to the JSFR Design

- 1,500 MWe large-scale Sodium Cooled FBR with MOX fuel,
- Innovative technologies for enhancement of reactor core safety, high economic competitiveness and countermeasures against specific issues of sodium



**MITSUBISHI FBR SYSTEMS, INC.**

## Framework of Safety Assurance

- (1) Prevention of abnormal occurrences    (2) Control abnormal operations    (3) Control accidents    (4) Manage severe accidents

		For DBE	For DEC	For DEC
<ul style="list-style-type: none"> <li>◆ Rational design margin</li> <li>◆ New technology (new material, seismic isolation etc)</li> <li>◆ Preventive maintenance</li> </ul>	Unreliability	$10^{-2}/d$ $10^{-4}/d$ $10^{-6}/d$	$10^{-1} \sim 10^{-2}/d$	$10^{-1} \sim 10^{-2}/d$
	Reactivity Control	Primary RSS ↔ Backup RSS		Containment Recriticality free core In-vessel core debris cooling by NC-DHRS
	RSS	SASS (Self Actuated Shutdown System)		IVR against typical CDA (ULOF)
	Heat Removal	Natural circulation (NC) DHRS ↔ Accident Management		Containment building + confinement Mitigate radiological consequences

Against chemical reaction of sodium

◆ Sodium leak -> leak-tight guard vessel & pipes

◆ SG tube leak -> double wall tube, early detection & rapid depression of steam-water side

**MITSUBISHI FBR SYSTEMS, INC.**

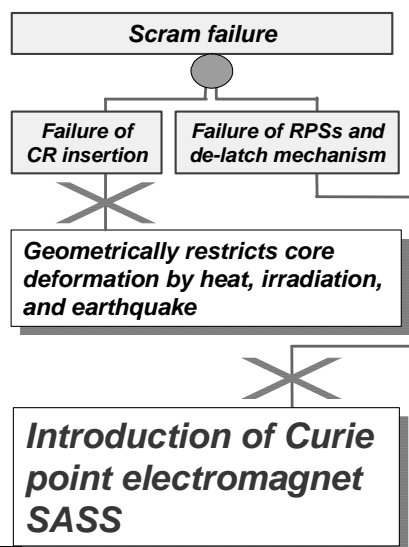
## Safety Design of JSFR -Reactor Shutdown Function-

<b>Primary RSS</b>	<b>Active system against DBEs</b>	<b>◆ Independence and diversity are taken into account</b> <ul style="list-style-type: none"> <li>· Driving force for rod insertion</li> <li>· De-latch mechanism</li> <li>· Detector</li> </ul>
<b>Backup RSS</b>		
<b>SASS</b>	<b>Passive shutdown capability against DECs (ATWS)</b>	<b>◆ Introduced as a passive shutdown mechanism to the de-latch device of the backup RSS</b>  <b>◆ Curie point electromagnet SASS was introduced</b>

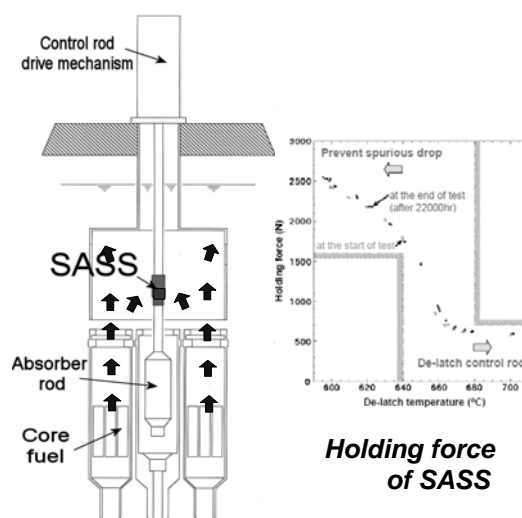
**MITSUBISHI FBR SYSTEMS, INC.**

## Safety Design of JSFR -Passive Shutdown System (SASS) 1/2-

### Introduction of SASS



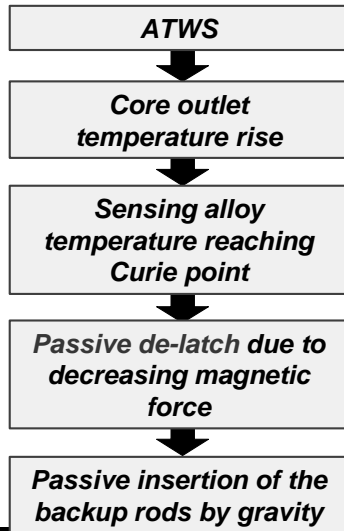
### Mechanism of SASS



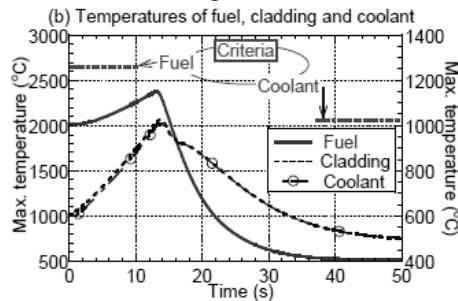
**MITSUBISHI FBR SYSTEMS, INC.**

## Safety Design of JSFR -Passive Shutdown System (SASS) 2/2-

**Feasibility of SASS against ATWS** *Irradiation test in experimental FR "JOYO"*



**Calculation result of ULOF in activating SASS at 680 °C**



MITSUBISHI FBR SYSTEMS, INC.

## Safety Design of JSFR -Core Cooling Function 1/2-

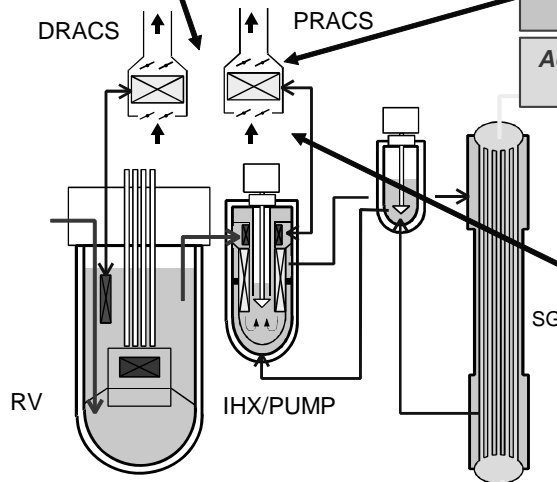
<b>Fully passive DHRS</b>	<b>Against DBEs</b>	<p>◆ <b>Redundancy and diversity are taken into account</b></p> <ul style="list-style-type: none"> <li>· Redundant system (1DRACS+2PRACS)</li> <li>· Redundant and divers A/C damper</li> </ul>
	<b>Against DECes</b>	
<b>Accident managements</b>		<p>◆ <b>Sufficient grace period is expected on the event sequence</b></p> <p>◆ <b>Measures for AMs are considered to reduce those occurrence frequency</b></p> <ul style="list-style-type: none"> <li>· Additional A/C damper for AM</li> <li>· Operation of A/C blower (non-safety class)</li> </ul>

MITSUBISHI FBR SYSTEMS, INC.

## Safety Design of JSFR -Core Cooling Function 2/-

### Design of DHRs

Redundant DHRs (1DRACS+2PRACS)



Redundant and divers damper of A/C (50%X2 in parallel)

Additional A/C damper for AM

Operation under fully passive condition (No blower and pump)

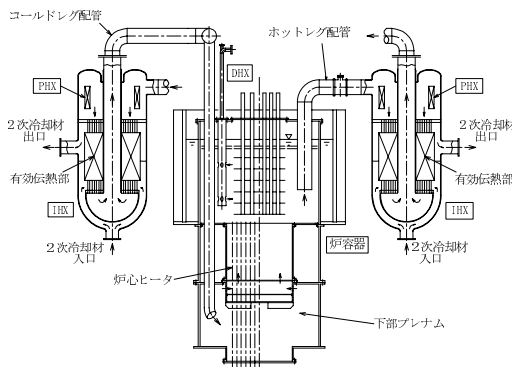
A/C blower for AM (non-safety class)

**MITSUBISHI FBR SYSTEMS, INC.**

## Safety Design of JSFR -Fully Passive DHRs by NC-

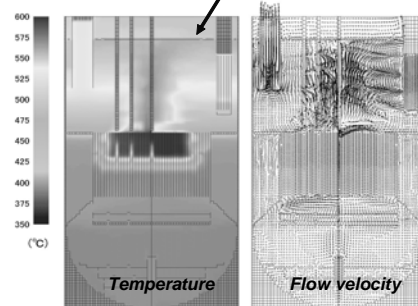
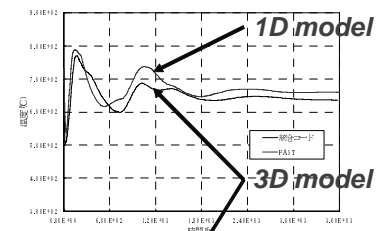
### R&D activities for NC

- ◆ 1/10 scaled water test
- ◆ 1/5 scaled partial sodium test



1/10 scale water test facility

### Calculation result of "Loss of offsite power"

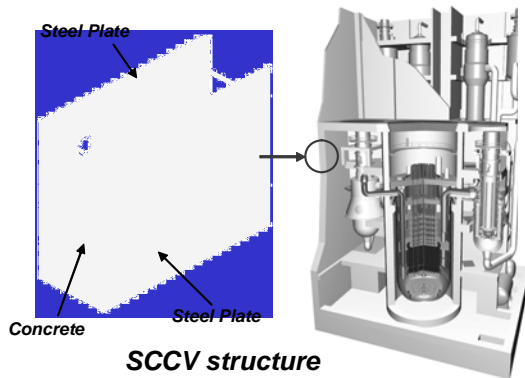


**MITSUBISHI FBR SYSTEMS, INC.**

## Safety Design of JSFR -Containment Function-

### Containment design

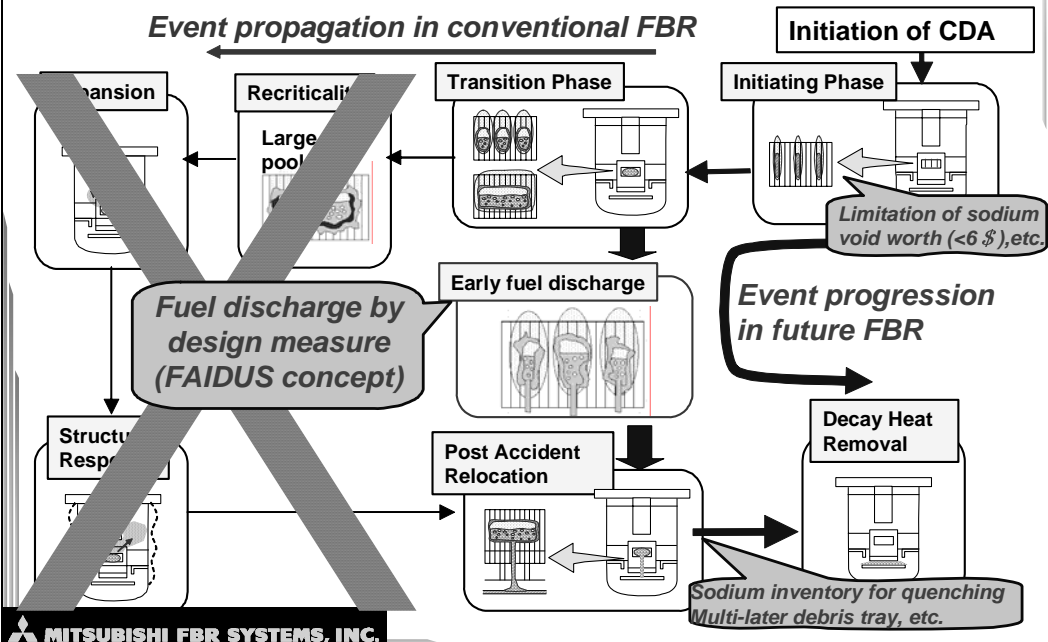
- ◆ No significant load within DBEs
  - No core damage
  - No sodium spillage
- ◆ Simple and compact SCCV
- ◆ In-Vessel Retention (IVR) should be pursued under the condition of DEC



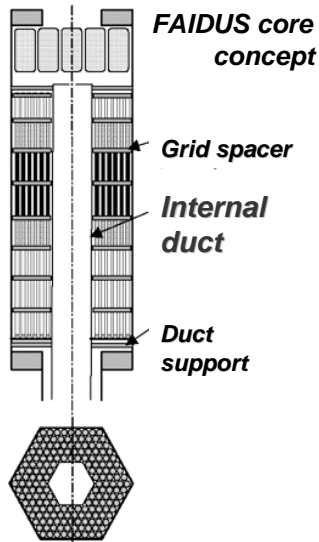
IVR against typical CDA  
(ULOF: Unprotected Loss Of Flow)

**Recriticality Free  
Core Design**

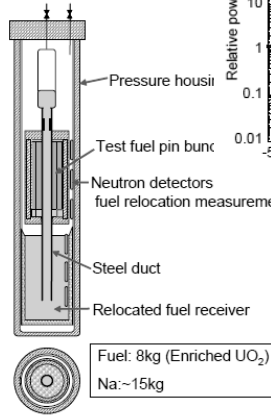
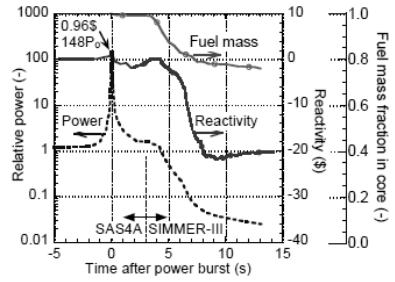
## Safety Design of JSFR -Event Propagation of Typical CDA-



# Safety Design of JSFR -Design Measures Aiming at IVR-



**Calculation result of ULOF with modified FAIDUS**



**EAGLE in-pile test using IGR**





**STRATEGIC DECISIONS ON RESEARCH FOR ADVANCED REACTORS:  
USNRC PERSPECTIVE**

**Mr. Michael Johnson**  
*USNRC, United States*



## **Advanced Reactor Research**

---

- Advanced reactors fundamentally different from LWRs
- Regulatory tools (codes, data, etc.) not applicable to advanced designs
- Constrained by reduced research budgets



## Safety Research Perspective

---

- Regulator must decide:
  - What are the key safety and risk issues for the design
  - How do we assure all issues have been identified
  - Which issues require experimental data



## Applicant Testing Programs

---

- Licensee/Applicant testing programs do not answer all questions
  - Scaling questions
  - Unable to simulate all components
  - Beyond design basis performance
- Regulators conducted independent research to address these questions



## Current Proposed Schedules

---

- Regulators will not have the same degree of data as is available for LWRs
- Current prospects in the U.S.A.
  - PBMR pre-application review – ongoing
  - PBMR design certificate applicants – late 2009
  - Toshiba 4S pre-application review – soon
  - Toshiba 4S design capability – late 2009
  - Hyperion Hydride reactor pre-application review – soon
  - NGNP gas-cooled reactor – design certificate applicants – 2011
  - GNEP Liquid Metal Burner Reactor - ??



## Current Proposed Schedules (continued)

---

- Unlikely that regulators will have tools in time to support applications
- Regulators will depend on applicants
- Conservatism will be needed on issues with uncertainties

## How to Proceed?

---

- Work together to identify needed capabilities and tools
- International cooperative research is the only practical way
- Explore use of industry facilities
- CSNI is good at coordinating research
- Recommend establishing a task group to identify and prioritize research needs

## LIST OF PARTICIPANTS

### AUSTRALIA

Mr. Thomas Vincent DIAMOND  
Manager, Nuclear Installations  
ARPANSA  
Nuclear Safety Agency  
Post Office Box 655, 38-40 Urunga Parade  
Miranda NSW 1490

Tel: +61 2 9541-8332  
Fax: +61 2 9541-8348  
Eml: vince.diamond@arpansa.gov.au

### CANADA

Mr. Andrei BLAHOIANU  
Director, Engineering Design Assessment  
Canadian Nuclear Safety Commission (CNSC)  
P.O. Box 1046 – Station B  
280 Slater Street,  
Ottawa, Ontario, K1P 5S9

Tel: +1 613 749 5908  
Fax: +1 613 995 5086  
Eml: andrei.blahoianu@cnsccsn.gc.ca

Mr. Andrew WHITE  
Director  
Reactor Safety Division  
AECL  
Chalk River Laboratories  
Chalk River, Ontario K0J 1J0

Tel: + 613 584 8811  
Fax: + 613 584 4200  
Eml: whitea@aecl.ca

### CZECH REPUBLIC

Dr. Frantisek PAZDERA  
Director General  
Nuclear Research Institute REZ plc  
Husinec 130  
250 68 Rez

Tel: +420 2 209 40 619  
Fax: +420 2 209 40 840  
Eml: paz@nri.cz

### FINLAND

Dr. Marja-Leena JARVINEN  
Deputy Director  
Radiation and Nuclear Safety Authority (STUK)  
P.O. Box 14  
00881 Helsinki

Tel: +358 9 759 88 304  
Fax: +358 9 759 88 382  
Eml: marja-leena.jarvinen@stuk.fi

Dr. Kirsi LEVA  
Senior Advisor  
Radiation and Nuclear Safety Authority (STUK)  
P.O. Box 14  
00881 Helsinki

Tel: +358 9 759 88 606  
Fax: +358 9 759 88 382  
Eml: Kirsi.Leva@stuk.fi

Dr. Lasse REIMAN  
Director  
Radiation and Nuclear Safety Authority (STUK)  
P.O. Box 14  
00881 Helsinki

Tel: +358 9 75988379  
Fax: +358 9 75988382  
Eml: lasse.reiman@stuk.fi

Mr. Keijo VALTONEN  
Head of Reactor & System Engineering Office  
Finnish Centre for Radiation  
and Nuclear Safety (STUK)  
P.O. Box 14  
00881 Helsinki

Tel: +358 9 759 88 331  
Fax: +358 9 759 88 382  
Eml: keijo.valtonen@stuk.fi

Mr. Timo VANTTOLA  
Technology Manager  
Technical Research Centre of Finland (VTT)  
Lampomiehenkuja 3A, Espoo  
P.O.Box 1000  
02044 VTT

Tel: +358 20 722 5020  
Fax: +358 20 722 5000  
Eml: timo.vanttola@vtt.fi

## **FRANCE**

Mr. Claude BARBALAT  
ASN/International Relations Department  
6 Place du Colonel Bourgoin  
75572 Paris Cedex 12

Tel: +33 1 40 19 71 72  
Fax:  
Eml: claud.barbalat@asn.fr

Mr. Noel CAMARCAT  
Production Ingénierie, Affaires nucléaires  
EDF site de Cap Ampère  
1 Place Pleyel  
93282 Saint-Denis Cedex

Eml: noel-extern.camarcat@edf.gdf.fr

Mr. Jean-Louis CARBONNIER  
Directeur du développement et de l'innovation nucléaire  
Direction de l'énergie nucléaire  
CEA – Centre de Saclay  
91191 Gif-sur-Yvette Cedex

Tel: +331 69 08 63 43  
Fax: +331 69 08 58 91  
Eml: jean-louis.carbonnier@cea.fr

Ms. Marie-Pierre COMETS  
Commissionner  
Autorité de sûreté nucléaire (ASN)  
6, place du Colonel Bourgoin  
75572 Paris Cedex 12

Tel: +33 1 40 19 88 46  
Fax: +33 1 40 19 86 09  
Eml: marie-pierre.comets@asn.fr

Mr. Robert DALLENDRE  
DSDRE/DRI Clamart  
IRSN  
BP 17  
92265 Fontenay-aux-Roses Cedex

Tel: +33 01 58 35 80 16  
Fax: +33 01 58 35 39 89  
Eml: robert.dallendre@irsn.fr

Dr. Michel DURIN  
Program Manager Reactors  
Nuclear Energy Division  
CEA/DEN/DSNI – Bâtiment 121  
Centre de Saclay  
91191 Gif-sur-Yvette Cedex

Tel: +33 1 69 08 62 15  
Fax: +33 1 69 08 58 70  
Eml: michel.durin@cea.fr

Mr. Bernard FOUREST  
Senior Safety Advisor  
Nuclear Engineering Division  
EDF Site de Cap Ampère  
1 place Pleyel  
93282 Saint-Denis Cedex

Tel: +33 1 43 69 45 08  
Fax: +33 1 43 69 04 80  
Eml: bernard.fourest@edf.fr

Mr. Jean-Pierre HUTIN  
Vice President, Power Generation Sector, EDF  
Centre de Chatou  
6 quai Wattier  
78400 Chatou

Tel: +33 1 30 87 79 46  
Fax: +33 1 43 69 34 95  
Eml: jean-pierre.hutin@edf.fr

Dr. Jean Claude MICAELLI  
Deputy Director  
IRSN/DPAM/DIR  
CE Cadarache – Bt 250,  
BP3  
13115 Saint-Paul-lez-Durance Cedex

Tel: +33 4 42 19 96 13  
Fax: +33 4 42 19 91 57  
Eml: jean-claude.micaelli@irsn.fr

Mr. Jacques REPUSSARD  
Director General  
IRSN – Centre d'études nucléaires  
77-83 Avenue du Général de Gaulle  
B.P. 17  
92262 Fontenay-aux-Roses Cedex

Tel: +33 1 58 35 84 89  
Fax: +33 1 58 35 71 52  
Eml: jacques.repussard@irsn.fr

Mr. Michel SCHWARZ  
Director  
IRSN/DPAM  
CE Cadarache – Bt 250  
BP3  
13115 Saint-Paul-lez-Durance Cedex

Tel: +33 04 4219 9689  
Fax: +33 04 4219 9157  
Eml: michel.schwarz@irsn.fr

## **GERMANY**

Dr. Axel BREEST  
Gesellschaft für Anlagen und  
Reaktorsicherheit (GRS) mbH  
Schwertnergasse 1  
50667 Köln

Tel: + 49 221 2068 667  
Fax: 49 221 2068 629  
Eml: Axel.Breest@grs.de

Mr. Lothar HAHN  
Director, GRS mbH  
Schwertnergasse, 1  
50667 Köln

Tel: +49 221 20 68 705  
Fax: +49 221 20 68 704  
Eml: Lothar.Hahn@grs.de

Dr. Michael HERTTRICH  
Federal Ministry for the Environment,  
Nature Conservation and Nuclear Safety  
Multilateral Regulatory Cooperation  
Robert-Schuman Platz, 3  
53175 Bonn

Tel: +49 228 99 305 2880  
Fax: +49 228 99 10 305 2880  
Eml: michael.herttrich@bmu.bund.de

Dr. Hartmut KLONK  
Bundesamt für Strahlenschutz  
Fachbereich Sicherheit in der Kerntechnik (SK)  
Fachgebiet SK 1  
Postfach 10 01 49  
38201 Salzgitter

Tel: +49 3018 333 1530  
Fax: +49 3018 10 333 1530  
Eml: hklonk@bfs.de

Dr. Michael MAQUA  
Gesellschaft für Anlagen- und Reaktorsicherheit mbH  
Schwertnergasse 1  
50667 Köln

Tel: +49 221 2068 718  
Fax: +49 221 2068 704  
Eml: michael.maqua@grs.de

Mr. Victor TESCHENDORFF  
Head, Reactor Safety Research Division  
Gesellschaft für Anlagen- und Reaktorsicherheit  
Forschungsinstitute  
85748 Garching

Tel: +49 89 32004 423  
Fax: +49 89 32004 599  
Eml: Victor.Teschendorff@grs.de

Dr. Stefan SCHIELKE  
Federal Ministry for the Environment,  
Nature Conservation and Nuclear Safety  
Multilateral Regulatory Cooperation  
Robert-Schuman Platz,3  
53175 Bonn

Tel: +49 22899 305 2887  
Fax: +49 22899 305 2882  
Eml: Stefan.Schielke@bmu.bund.de

Mr. Reinhard ZIPPER  
Head of Research Management Division  
Gesellschaft für Anlagen-und  
Reaktorsicherheit (GRS) mbH  
Schwertnergasse 1  
50667 Köln

Tel: +49 221 2068 720  
Fax: +49 221 2068 629  
Eml: reinhard.zipper@grs.de

## **HUNGARY**

Dr. Janos GADO  
Director  
KFKI Atomic Energy Research Institute  
P.O.Box 49  
Konkoly Thege M. út 29/33  
1525 Budapest

Tel: +36 1 395 9159  
Fax: +36 1 395 9293  
Eml: gado@sunserv.kfki.hu



Dr. Ivan LUX  
Director General  
Hungarian Atomic Energy Authority  
Head of Nuclear Safety Inspectorate  
1036 Budapest, Fényes A. u. 4.  
1525 Budapest, Pf. 49

Tel: +36 1 436 4881  
Fax: +36 1 436 4883  
Eml: lux@haea.gov.hu

Mr. Ivan TOTH  
Head, Thermal-Hydraulics Laboratory  
KFKI  
Atomic Energy Research Institute  
POB 49  
1525 Budapest, 114

Tel: +36 1 392 2294  
Fax: +36 1 3959 293  
Eml: tothi@sunserv.kfki.hu

### **ITALIE**

Dr. Fosco BIANCHI  
FPN Department  
Martiri di Monte Sole, 4  
40129 Bologna

Tel: +39 051 6098 426  
Fax: +39 051 6098 279  
Eml: fosco.bianchi@bologna.enea.it

### **JAPAN**

Dr. Kiyoharu ABE  
Technical Counselor  
Japan Nuclear Energy Safety Organization (JNES)  
TOKYU REIT Toranomom Bldg.  
3-17-1, Toranomom, Minato-ku  
Tokyo, 105-0001

Tel: +81 3 4511 1134  
Fax: +81 3 4511 1298  
Eml: abe-kiyoharu@jnes.go.jp

Dr. Toyoshi FUKETA  
Unit Manager, Reactor Safety Research Unit  
Nuclear Safety Research Center  
Japan Atomic Energy Agency  
Tokai-mura, Naka-gun, Ibaraki-ken  
319-1195 Japan

Tel: +81 29 282 5277  
Fax: +81 29 282 5429  
Eml: fuketa.toyoshi@jaea.go.jp

Mr. Masanobu KATO  
Deputy Director  
International Affairs Office  
NISA/METI  
1-3-1 Kasumigaseki, Chiyoda-ku  
Tokyo 100-8986

Tel: +81 3 3501 1087  
Fax: +81 3 3580 5971  
Eml: kato-masanobu@meti.go.jp

Mr. Yoshio KAWAGUCHI  
First Secretary, Scientific Affairs  
Permanent Delegation of Japan  
to the OECD  
11, Avenue Hoche  
FR-75008 Paris

Tel: +33 1 53 76 61 81  
Fax: +33 1 45 63 05 44  
Eml: kawaguchi@deljp-ocde.fr

Mr. Shoji KOTAKE  
Advanced Nuclear System Res. and Dev. Dir.  
O-arai Research and Development Center  
FBR System Engineering Unit,  
FBR System Design Group  
4002, Narita, Oarai, Ibaraki-Pref., 311-1393

Tel: +81 29 267 4141  
Fax: +81 29 267 1676  
Eml: kotake.shoji@jaea.go.jp

Mr. Takashi NISHIYAMA  
General Affairs Division  
Secretariat of the Nuclear Safety Commission  
Cabinet Office  
3-1-1 Kasumigaseki, Chiyoda-ku  
Tokyo 100-8970

Tel: +81 3 3581 9918  
Fax: +81 3 3581 9835  
Eml: takashi.nishiyama@cao.go.jp

Dr. Yoshihiro OZAWA  
International Affairs Group  
Safety Information Research  
Japan Nuclear Energy Safety Organization (JNES)  
Fujita Kanko Toranomom Bldg., 3-17-1  
Toranomom, Minato-ku, Tokyo, 105-0001

Tel: +81 3 4511 1912  
Fax: +81 3 4511 1998  
Eml: ozawa-yoshihiro@jnes.go.jp

Mr. Yoshio SHIMAKAWA  
Manager, Reactor Safety and Control System Group,  
Reactor Core and Safety Design Department,  
Mitsubishi FBR Systems, Inc. (MFBR)

Tel: +81 3 6439 4366  
Fax: +81 3 6439 4399  
Eml: yoshio\_shimakawa@mfbf.mhi.co.jp

Dr. Kunihisa SODA  
Commissioner, Nuclear Safety Commission  
The Cabinet Office  
3-1-1 Kasumigaseki, Chiyoda-ku  
Tokyo 100-8970

Tel: +81 3 3581 3470  
Fax: +81 3 3581 3475  
Eml: kunihisa.soda@cao.go.jp

Mr. Nobuo TANAKA  
Senior Researcher, Safety Analysis & Evaluation Div.  
Japan Nuclear Energy Safety Organization (JNES)  
Kamiya-cho Mt Bldg., 12F  
4-3-20, Toranomom, Minato-ku  
Tokyo 105-0001

Tel: +81 3 4511 1560  
Fax: +81 3 4511 1598  
Eml: tanaka-nobuo@jnes.go.jp

Mr. Tomoho YAMADA  
Nuclear Safety Regulatory Standard Division  
Nuclear and Industrial Safety Agency  
Ministry of Economy, Trade and Industry  
Kasumigaseki 1-3-1 Chiyoda-ku  
Tokyo 100-8986

Tel: +81 3 3501 0621  
Fax: +81 3 3501 5971  
Eml: yamada-tomoho@meti.go.jp

Mr. Uichiro YOSHIMURA  
Director, Nuclear Safety Public Relations  
and Training Division  
Nuclear and Industrial Safety Agency (NISA)  
Ministry of Economy, Trade and Industry (METI)  
1-3-1 Kasumigaseki, Chiyodaku,  
Tokyo 100-8986

Tel: +81 3 3501 5890  
Fax: +81 3 3580 8434  
Eml: yoshimura-uichiro@meti.go.jp

## **KOREA**

Dr. Jaejoo HA  
Vice President, Nuclear Safety Research  
Korea Atomic Energy Research Institute (KAERI)  
1045 Daedeokdaero, Yuseong-gu  
Daejeon, 305-353

Tel: +82 42 868 2755  
Fax: +82 42 868 8583  
Eml: jjha@kaeri.re.kr

Dr Yong-Ho RYU  
Director, Regulatory Research Division  
Korea Institute of Nuclear Safety (KINS)  
PO BOX 114, Yuseong  
Taejeon, 305-600

Tel: +82 42 868 0020  
Fax: +82 42 861 1700  
Eml: ryh@kins.re.kr

## **NETHERLANDS**

Mr. Robert JANSEN  
VROM – Inspection  
Division of Nuclear Safety, Security and Safeguard  
Department Manager Power Reactors Supervisor  
Rijnstraat 8 – P.O. Box 16191/IPC 560  
2500 BD The Hague

Tel: +31 70 3392 487  
Fax: +31 70 3391 887  
Eml: rob.jansen@minvrom.nl

Dr. Victor A. WICHERS  
Department Manager, Safety & Performance  
Nuclear Research & Consultancy Group (NRG)  
Westerduinweg 3, Postbus 25  
1755 ZG Petten

Tel: +31 (0) 224 564656  
Fax: +31 (0) 224 568490  
Eml: wichers@nrg-nl.com

## **PORTUGAL**

Prof. Jose CARVALHO SOARES  
Centro de Fisica Nuclear da  
Universidade de Lisboa  
Avenida Prof. Gama Pinto 2  
1649-003 Lisboa

Tel: +351 21 790 4985  
Fax: +351 21 795 4288  
Eml: soaresjc@cii.fc.ul.pt

## **SPAIN**

Mr. Antonio COLINO MARTINEZ  
Commissioner  
Consejo de Seguridad Nuclear (CSN)  
Justo Dorado, 11  
28040 Madrid

Tel: +34 91 346 04 03  
Fax: +34 91 346 03 77  
Eml: acm@csn.es

Mr. Jose Manuel CONDE LOPEZ  
Jefe de Area Ingenieria Nuclear  
Consejo de Seguridad Nuclear  
C/ Justo Dorado 11  
28040 Madrid

Tel: +34 91 3460253  
Fax: +34 91 3460588  
Eml: jmcl@csn.es

Mr. Francisco FERNANDEZ MORENO  
Commissioner  
Consejo de Seguridad Nuclear (CSN)  
Justo Dorado, 11  
28040 Madrid

Tel: +34 91 346 0330  
Fax: +34 91 346 0396  
Eml: ffrmr@csn.es

Dr. Isabel MELLADO  
Consejo de Seguridad Nuclear  
c/Justo Dorado 11  
28040 Madrid

Tel: +34 91 346 0303  
Fax: +34 91 346 0588  
Eml: imj@csn.es

## **SWEDEN**

Mr. Lennart CARLSSON  
Swedish Nuclear Power Insp. (SKI)  
Klarabergsviadukten 90  
10658 Stockholm

Tel: +46 8 698 8489  
Fax: +46 8 661 9086  
Eml: lennart.carlsson@ski.se

Prof. Tomas LEFVERT  
Senior Scientific Adviser  
Vattenfall AB, Nordic Generation  
16287 Stockholm

Tel: +46 87395355  
Fax: +46 87396482  
Eml: tomas.lefvert@vattenfall.com

Dr. Gustaf LOWENHJELM  
Director of Research  
Swedish Nuclear Power Inspectorate  
10658 Stockholm

Tel: +46 8 698 8496  
Fax: +46 8 661 9086  
Eml: gustaf.lowenhielm@ski.se

## **SWITZERLAND**

Dr. Jean-Marc CAVEDON  
Head of Nuclear Energy & Safety Department  
Paul Scherrer Institut  
Villigen PSI  
5232 Villigen

Tel: +41 56 310 2742  
Fax: +41 56 310 4411  
Eml: jean-marc.cavedon@psi.ch

Dr. Georg SCHWARZ  
Deputy Director  
Swiss Federal Nuclear Safety Inspectorate (HSK)  
5232 Villigen-HSK

Tel: +41 5631 03902  
Fax: +41 5631 03995  
Eml: Georg.Schwarz@hsk.ch

Mr. Martin ZIMMERMANN  
Deputy Head  
Laboratory for Reactor Physics and  
Systems Behaviour  
Paul Scherrer Institut  
5232 Villigen PSI

Tel: +41 56 310 27 33  
Fax: +41 56 310 23 27  
Eml: martin.zimmermann@psi.ch

## **UNITED KINGDOM**

Dr. Mike WEIGHTMAN  
HM Chief Inspector of Nuclear Installations  
4N.1 Redgrave Court  
Merton Road, Bootle, Merseyside L20 7HS

Tel: +44 151 951 4170  
Fax: +44 151 951 3492  
Eml: mike.weightman@hse.gsi.gov.uk

## **UNITED STATES**

Mr. Bill BORCHARDT  
Director, Office of New Reactors  
US Nuclear Regulatory Commission  
MS-0-5E7  
Washington, D.C. 20555

Tel: +1 301 415 1897  
Fax: +1 301 415 8333  
Eml: rwb1@nrc.gov

Mr. Michael JOHNSON  
US Nuclear Regulatory Commission  
Office of Nuclear Regulatory Research  
11545 Rockville Pike, Mail Stop T-10 F-12  
Rockville, Maryland 20852

Tel: +1 301 415 0774  
Fax: +1 301 415 3707  
Eml: mrj1@nrc.gov

Mrs. Donna-Marie PEREZ  
CEE Program Manager  
U.S. Nuclear Regulatory Commission  
Rockville, MD 20852

Tel: +1 301 415 2848  
Fax: +1 301 415 2395  
Eml: dmp@nrc.gov

Dr. Rosa YANG  
Nuclear Power Division, Electric Power Research Inst.  
3412 Hillview Ave  
P.O. Box 10412  
Palo Alto, CA 94303

Tel: +1 650 855 2481  
Fax: +1 650 855 1026  
Eml: ryang@epri.com

## **SLOVENIA**

Dr. Borut MAVKO  
Head, Reactor Engineering Division  
Institut "Jozef Stefan"  
Jamova 39  
1000 Ljubljana

Tel: +386 1 5885 330  
Fax: +386 1 5885 377  
Eml: borut.mavko@ijs.si

## **International Organisations**

### **European Commission (EC)**

Dr. Michel BIETH  
Unit Head, Nuclear Operation Safety Institute for Energy  
DG Joint Research Center European Commission  
P.O.Box 2  
NL-1755 ZG Petten

Tel: +31 22 456 5157  
Fax: +31 22 456 5637  
Eml: michel.bieth@ec.europa.eu

Dr. Michel HUGON  
European Commission  
DG Research J-2, CDMA 1/52  
BE-1049 Bruxelles

Tel: +32 2 296 57 19  
Fax: +32 2 295 49 91  
Eml: Michel.Hugon@ec.europa.eu

### **International Atomic Energy Agency**

Dr. Mamdouh EL-SHANAWANY  
International Atomic Energy Agency  
Head of Safety Assessment Section  
Wagramerstrasse 5 – P.O. Box 100  
A-1400 Vienna

Tel: +431 2600 22726  
Fax: +431 2600 7 22726  
Eml: m.el-shanawany@iaea.org

### **OECD Nuclear Energy Agency**

Le Seine Saint-Germain  
12, boulevard des Îles  
FR-92130 Issy-les-Moulineaux

Mr. Luis ECHAVARRI  
Director-General

Tel: +33 1 45 24 10 01  
Fax: +33 1 45 24 11 10  
Eml: luis.echavarri@oecd.org

Mrs. Janice DUNN LEE  
Deputy Director-General

Tel: +33 1 45 24 10 02  
Fax: +33 1 45 24 11 15  
Eml: janice.dunnlee@oecd.org

Mr. Takanori TANAKA  
Deputy Director

Tel: +33 1 45 24 10 04  
Fax: +33 1 45 24 11 06  
Eml: Takanori.tanaka@oecd.org

Mr. Jean GAUVAIN  
Nuclear Safety Division

Tel: +33 1 45 24 10 52  
Fax: +33 1 45 24 11 29  
Eml: jean.gauvain@oecd.org

Mr. Alejandro HUERTA  
Nuclear Safety Division

Tel: +33 1 45 24 10 57  
Fax: +33 1 45 24 11 29  
Eml: alejandro.huerta@oecd.org

Mr. Barry KAUFER  
Nuclear Safety Division

Tel: +33 1 45 24 10 55  
Fax: +33 1 45 24 11 29  
Eml: barry.kaufer@oecd.org

Mr. Han-Chul KIM  
Nuclear Safety Division

Tel: +33 1 45 24 10 39  
Fax: +33 1 45 24 11 29  
Eml: han-chul.kim@oecd.org

Mr. Javier REIG  
Head, Nuclear Safety Division

Tel: +33 1 45 24 10 50  
Fax: +33 1 45 24 11 29  
Eml: javier.reig@oecd.org

Mr. Willem VAN DOESBURG  
Nuclear Safety Division

Tel: +33 1 45 24 10 58  
Fax: +33 1 45 24 11 29  
Eml: willem.vandoesburg@oecd.org

Mr. Carlo VITANZA  
Nuclear Safety Division

Tel: +33 1 45 24 10 62  
Fax: +33 1 45 24 11 29  
Eml: carlo.vitanza@oecd.org

Mr. Akihiro YAMAMOTO  
Nuclear Safety Division

Tel: +33 1 45 24 10 56  
Fax: +33 1 45 24 11 29  
Eml: akihiro.yamamoto@oecd.org

OECD PUBLICATIONS, 2 rue André-Pascal, 75775 PARIS CEDEX 16  
Printed in France.